

II - NYS 4-H Horse Bowl Contest

Rules and Regulations

****Note: National Rule changes will be automatically reflected in New York State 4-H educational event rules in following years.****

The primary objective of Horse Bowl contests is to provide an opportunity for youth enrolled in 4-H horse projects to demonstrate their knowledge of equine related subject matter in a competitive setting where attitudes of friendliness and fairness prevail. It is also hoped that these contests will provide educational experiences for both participants and spectators.

DRESS CODE

A strict dress code will be enforced. Clean, neat clothing appropriate for the event and weather conditions will be expected. Remember, contestants are representing 4-H, Cornell, and their county and region. Shirt must have sleeves and cover midriff. No inappropriate language on clothing. Skirts and shorts must be longer than the individual's fingertips when their hands are at their sides.

SELECTION OF TEAMS, CONTESTANTS AND ELIGIBILITY

Regional Contests:

1. Teams to compete in regional contests may be selected by any means agreeable to the majority of counties within that region. Regions are encouraged to allow as many youth as possible to participate in regional competitions. Each team consists of no less than four (4), but no more than six (6) members. Regions are advised to follow state rules, but may alter to fit their needs. All teams competing in state and national contests must conform to state and national rules.
 - a. **Seniors:** Senior contestants must be at least 14 years of age but not yet 19 years of age by January 1 of the current calendar year and must never have been member of an official Horse Bowl Team representing New York State at an out-of-state Horse Bowl contest, nor have participated in a National 4-H Horse Bowl Contest.
 - b. **Juniors:** Junior contestants must not have achieved their 14th birthday prior to January 1 of the current year.

Please note: For State events, a junior youth must have reached their 9th birthday prior to January 1 of the current calendar year.
 - c. **Novice (optional):** Contestants must not have achieved their 14th birthday prior to January 1 of the current calendar year **and** must never have participated in a Horse Bowl contest at the regional level. At the discretion of the region, exceptions may be made to allow contestants who are 9 years of age or less to compete. Youth 10 years and under may compete as a novice a maximum of 2 years.
2. All team members must be enrolled in a 4-H horse project in the county they represent.
3. Only four (4) team members may be seated at the panel at one time.

4. One or two (1 or 2) substitutions may be made during a match, depending on the number of members on the team. For substitution procedure see: **Playing Teams and Alternates.**

State Contests:

1. Two (2) Junior and two (2) Senior teams from each regional contest may enter the state contest. If a region decided to split into an A and B, each may send (1) Junior and (1) Senior team. How the regions select their teams is a regional decision.
2. Senior and Junior Divisions only will be held at the state level. Age descriptions will be the same as for Regional Contests.
3. Each team is allowed only one (1) substitution is permitted in each match.
4. Teams must consist of no less than four (4) but not more than six (6) members.
5. Only those members who participated at the regional contest are eligible to participate in the state contest.

National Contest:

1. The top five (5) eligible individuals winning the state contest will be entered in the national event.
 - a. Five (5) contestants may be entered in the national contest. The 6th place individual will be considered the alternate. The alternate will be a part of the state's entry in national competition if one of the five (5) designated national team members cannot participate.
 - b. The five (5) individuals invited to represent New York in the National 4-H Horse Bowl event will be selected among the high individuals in the state contest based on availability for additional training, availability for the contest and rank subject to confirmed eligibility.
 - c. Commitment of qualified participants to be a part of the national NYS 4-H Horse Bowl team must be made some time prior to the first day of State Fair. Once a commitment is made, this 4-H youth may not represent NYS in the national event in any other national contest during that contest year.
 - d. Members of the team representing New York in out-of-state competition become ineligible for further Horse Bowl competition.

REFERENCE MATERIALS USED FOR QUESTIONS

NOTE (11/08): In an instance where there is a conflict of information between sources, the most recent source (publication date) will prevail. For example, if there is a conflict between The Horse and Equine Science, Equine Science would be considered correct as it is a new publication.

- CODE:**
NHEC I **ILLUSTRATED DICTIONARY OF EQUINE TERMS, New Horizons Education Center, Inc.**
Alpine Publications, PO Box 7027, Loveland, CO 80537 - \$19.95
Phone: 1-800-777-7257 FAX: 970-667-9157
- EVANS 2ND** **THE HORSE: (2nd edition) by Evans, Borton, Hintz, Va**
VHPS Holtzbrinck Publishers, 16365 James Madison Hwy, Gordonsville, VA 22942
Phone: 888-330-8477 FAX: 800-672-2054
- AYHC 1st** **HORSE INDUSTRY HANDBOOK - the American Youth Horse Council**
Order from: The Equine Collection, PO Box 1539, Ft. Lee, NJ 07024-1539
Phone: 800-952-5813 FAX: 201-840-7242
- LEWIS 2nd** **FEEDING AND CARE OF THE HORSE (2nd Edition), by Lon Lewis**
Williams and Wilkens, PO Box 1496, Baltimore, MD 21298-9724
Phone: 800-638-0672
- H&H/HS** **NATIONAL 4-H MATERIAL: HORSES AND HORSEMANSHIP and HORSE SCIENCE, revised 2000.**
National 4-H Council/Supply Service, c/o First Union Bank, PO Box 75013, Baltimore, MD 21275-5013
Phone: 301-961-2934 FAX: 301-961-2937
For Junior and Novice only
- HPY HRS** **HAPPY HORSEMANSHIP, by Dorothy Henderson Pinch**
ISBN #0-88365-259-5
Breakthrough Publications, 310 N. Highland Ave., Ossining, NY 10562
Phone 800-824-5000
For Novice only
- AYHC Ld. Mn.** **YOUTH LEADER'S MANUAL, American Youth Horse Council**
Order from: The Equine Collection, PO Box 1539, Ft. Lee, NJ 07024-1539
Phone: 800-952-5813 FAX: 201-840-7242
- KAINER** **THE COLORING ATLAS OF HORSE ANATOMY, by Robert A. Kainer & Thomas O. McCracken.**
Alpine Publications, Inc., PO Box 7027, Loveland CO 80537
Phone: 970-667-2017
- GRIF** **EQUINE SCIENCE: BASIC KNOWLEDGE FOR HORSE PEOPLE OF ALL AGES by Jean T. Griffiths.**
www.HorseBooksEtc.com or 1-800-952-5813, or ISBN#978-1-929164-42-4 to order from your local bookstore.

SUPPLEMENTAL REFERENCES:

The [Dover Saddlery English Tack Catalog](#) and [Smith Brothers Western Tack Catalog](#) may be used as supplemental references. These catalogs provide visual representations for questions relating to tack.

[Dover Saddlery](#) – Apparel, tack and horse care items, for the English rider – request free catalog from www.DoverSaddlery.com or call toll free 1-888-234-6942.

[Smith Brothers](#) – Apparel, tack and horse care items, for the Western rider – request free catalog from www.SmithBrothers.com or call toll free 1-888-677-0450.

QUESTION TYPES:

1. **Regular Questions** are worth **two (2)** points during **one-on-one** competition, when only one member of each team may respond. Regular questions are worth **one (1)** point during **open** questions, when any member of either team may respond. These questions count toward individual and team scores. **All incorrect answers receive a -1 deduction.**
2. **Toss-up Questions** are worth **one (1)** point and are open for response to any member of either team. Toss-up questions are used in the **open** part of the match. If there is a correct answer to the toss-up question, a **bonus** question will be attached. Toss-up questions are generally a little more difficult than a regular question and may have 2 or 3 required answers. All answers are required to be correct. The points will count toward individual and team scores. **All incorrect answers receive a -1 deduction.**
3. **Bonus Questions** will be worth **three (3)** points. They are attached to a correctly answered toss-up question in the **open** part of the match. When multiple answers are required, **three (3)** points will be awarded if all of the required answers are correct. No points will be awarded or taken away if there is less than the required number of answers or if there are no correct answers. No part of the bonus question will be repeated, nor will any additional information be given to the contestants relative to the question. These points will count toward **team scores only.**
 - a. A bonus question attached to an unanswered or incorrectly answered toss-up question will be transferred to the next regular open question (which becomes the new toss-up question), until a correct answer is given.
 - b. The team should allow the moderator to read the complete question. The team will be given ten (10) seconds to confer. The acknowledger will call time at the end of ten (10) seconds. The team captain or designee must then start giving the required number of answers within five (5) seconds. Team members may give answers to the captain/designee during the 30-second answering period.
 - c. If the match ends with an unanswered bonus question, the bonus question will not be utilized.

READING AND ANSWERING QUESTIONS

1. The moderator will read all questions, identify the type and number of question and designate the chairs eligible to respond when necessary. **Five (5) seconds** will be allowed for starting a response. If an answer is not given or given incorrectly, the answer

will be given and the next question read. If the answer given is the same as or means the same as the expected answer, it will be accepted. If the answer is different than the expected answer, it will be referred to the judge's panel for decision.

2. Once a contestant activates a buzzer, they **must be acknowledged** before they can answer the question. Acknowledgment is either by name or number. After they have been acknowledged, the contestant has five seconds to start a valid answer. First answer will be considered valid answer.
 - a. **The first answer given** will be accepted as the official answer. Repeating the question will not be considered the initiation of an answer. It is the responsibility of the acknowledger and referee to determine if an actual answer was started within the 5-second time period.
 - b. **If a question is read to completion**, the judges may ask the contestant to explain, expand, or be more specific or to clarify their answer.
 - c. **An acknowledgment penalty of one (-1) point** will be deducted from the contestant's score and their team score, if they answer a question before being acknowledged.
3. **If a question is interrupted** during the reading of it, the moderator will stop reading as soon as a buzzer is activated. The contestant responding has **five (5) seconds after being acknowledged**, to begin their answer. If the answer given is correct for the way the question was written, it will be accepted. If the answer given is correct for only the portion of the question heard, but wrong for the way the question was written, the answer will not be accepted. If the question was interrupted, the judges will not be allowed to ask for any type of clarification of the answer given.
4. The judges panel will be allowed to verify an answer or the validity of a question. If verification cannot be made, the question will be replaced.

FIRST HALF PLAY (one-on-one questions)

1. **One-on-one questions:** Regular questions shall be addressed to only one member of each team, beginning with the contestants in the #1 Chairs (nearest to control operator) on either team and progressing with subsequent questions going to the contestants in the #2 chairs, #3 chairs, #4 chairs, respectively, until the one-on-one questions per contestant per match are finished.
 - a. The moderator shall clearly indicate the start of one-on-one by announcing the number of the contestants' chair eligible to respond, prior to reading the question
 - b. **If any contestant other than the two designated contestants responds**, that contestant and team will lose **two(-2) points**.
 - c. A contestant that responds more than twice to a on-on-one question directed to another contestant, will be replaced at the panel by their team alternate. If an alternate is not available, the remainder of the match will be played with less than a full team and all questions normally addressed to the eliminated contestant will be addressed to the contestant in the opposite numbered chair. The removed contestant may return to further matches in the contest. A third such penalty will disqualify them from the competition. The **two (-2) point**

penalty will continue to apply for 2nd and 3rd offense.

- d. Toss-up/Bonus questions will not be used during one-on-one competition.

SECOND HALF PLAY (Toss-Up Questions with Bonus)

1. During the second half of each match, the moderator will read the questions as during the first half except that **any member of either team is eligible to respond**.
2. All **regular/open** and **toss-up questions** will be open to all contestants seated at the game table during the second half. **Bonus questions** are open only to the team answering the toss-up questions correctly.
 - a. An **incorrect response** to a regular/toss-up question shall reduce the score of the individual and the team giving the incorrect response by **one (-1) point**.
3. If no member of either team activates a buzzer in response to a toss-up question, there shall be no loss of points or awarding of points to either team.
4. If the answer to a **toss-up** question is begun during the 5-second allowable time and the answer is **incorrect**, that team and individual lose **one (-1) point**.
 - a. A bonus question attached to an unanswered or incorrectly answered toss-up question will be transferred to the next regular open question, (which becomes the new toss-up question), until a correct answer is given.
 - b. The team should allow the moderator to read the complete question. The team will be given ten (10) seconds to confer. The acknowledger will call time at the end of ten (10) seconds. The team captain or designee must then start giving the required number of answers within five (5) seconds. Team members may give answers to the captain/designee during the 30-second answering period.
 - c. If the match ends with an unanswered bonus question, the bonus question will not be utilized.
5. If the answer to a toss-up question is **correctly answered** within the 5-second time period, that team and individual will be awarded **one (1) point**.
 - a. The moderator will then read the **bonus** question and a **10 second** discussion period will be permitted for team consultation to determine the answer. The team should allow the moderator to read the complete question. At the end of the 10-second time period a signal will be given by the timer. At the signal from the timer, a **5-second** period is then permitted for the team captain or one contestant designated by the captain to begin the answer. Team members may give answers to the captain/designee during the **30-second** answering period. The entire answer must be given by only one of the team members. Paper and pencil will be provided to the captains if needed.
 - b. Successful completion of the answer will result in that **team** being awarded the **three (3) points** designated for that bonus question. No individual points will be awarded for bonus questions.

- c. All parts of the bonus question must be answered correctly with **no partial points** permitted, regardless of the number of parts of the question answered correctly.
- d. **Failure to answer** a bonus question results in **no penalty** (loss of points) to the team.
- e. No part of the bonus question will be repeated, nor will any additional information be given to the contestants.

MATCH TIES

- 1. In the event of a match tie, it will be broken with **five (5)** tie breaker questions. If a tie remains, the first team to win a point (or because of a loss of a point by the other team, has a one point advantage) will be declared a winner based on the scores.
- 2. Tie breaking questions **do not count towards team, team bonus, or individual scores**. They are only used to break the tie.

ENDING THE MATCH

- 1. Following the final question, the team with the highest number of points shall be declared the winner of the match.
- 2. Once the moderator has declared a winner based on the scores, there shall be no protest. There shall be no protest of any questions or answers following the declaration of the winner in any match. The decisions of the judges panel will be final.

PLAYING TEAMS AND ALTERNATES

- 1. Only four (4) contestants shall be seated at the panel at any one time. Seat position must be declared prior to competition and youth must remain in this seat for the duration of the entire contest. The only exception is when an alternate replaces a seated player during a match of the competition. See #2 below.
- 2. During any match, only one (1) alternate may be replaced at the panel when:
 - a. The moderator, team captain, or team coach deems it impossible for one of the seated members to continue.
 - b. The captain/coach of a team requests the replacement of a team member.
- 3. The team member removed from a match becomes ineligible to return to that particular match. The team member removed and the replacement member are both eligible to participate in further matches. A five-member team is strongly recommended.
- 4. Members removed from the game table for disciplinary reasons, may not come back to any matches in the competition.

TEAM PARTICIPATION BONUS

1. In order to encourage full team participation, each team member will have a bonus card at the game table. When a team member gives a correct response to a one-on-one, regular/open, or toss-up question, that member will turn their card around to face the scorekeepers. A bonus worth **two(2) points** will be awarded to **the team** when all four bonus cards face the scorekeepers. The value of the question (1 or 2 points) will also be added to the score of the individual who answered the question, thus making that question worth three(3) or four (4) points, depending on the value of the question.

Example: The scorekeeper will add four (4) points to the team score, two(2) points for a correct answer to an one-on-one question and two (2) points for the team bonus. The contestant will receive the value of the question on their individual score, and the team will receive both the individual points and the bonus points on the team score.

- a. When an alternate comes to the game table, if a bonus card is showing for that chair, it must be forfeited (turned around) and earned by the contestant coming into the match. If a bonus card is not showing when the replacement comes into the match, this contestant will have the opportunity to earn their share of the bonus with a correct answer.
- b. When a team bonus has been earned once, the bonus cards will be turned around and the team has an opportunity to earn it again. A team may earn this bonus as many times as possible within a match.

TIME OUTS

1. The **team captain, coach, or any staff member** may call for a “time out” for clarification of a rule, score, to seat an alternate or allow for any unexpected problems. “Time outs” may be called only after a question has been answered and before the next question starts.

HOLDING ROOMS

1. All team members, alternates, and coaches must remain in the designated holding area until it is their turn to play.
 - a. After their round match is played, they must go to an appropriate designated area until the conclusion of the round in progress.
 - b. After the round is completed, all team/alternates and coaches not eliminated from the contest, must return to the designated holding area to await their next match.
 - c. All coaches in the holding area are responsible for supervision of the teams. These rules are a manner of ethics and require the cooperation of all team members and coaches.

CONTEST PROCEDURES

1. Teams are assembled and seated at their respective panels, with the designated team captain seated in the number 1 chair, nearest to the middle or the acknowledged. Each contestant is given the opportunity to check the equipment.
2. All team members will have a participation bonus card facing the contestant. They will be blank to the scorekeepers until that contestant gives a correct response to a question. At that time the card will be turned toward the scorekeeper.
3. The designated set of questions for each round is reviewed by the moderator and verified with the judges panel and referee before starting the game. Prior to reading a question, the moderator will announce the number, type of question and the contestant eligible to respond. Each succeeding question will be read in this manner until all of the questions for that match are read. The correct answer will be given for all unanswered questions or wrong answers.
4. Contestants who responds to a question will receive the appropriate points applied to a particular question. Appropriate penalties will be deducted as warranted.
5. If the answer to any question is correct, the team will also receive the appropriate points applied to a particular question. Appropriate penalties will also be deducted as warranted.
6. If the time (five (5) seconds) in which to answer a question elapses without a contestant activating a buzzer, there shall be no loss or awarding of points to either team. After the response time has elapsed, the answer will be given and the next question read.
7. If the buzzer is activated and an **answer not started within the 5-second allowable time**, there will be a **minus two (-2) point penalty** imposed against the contestant who activated the buzzer and their team.
8. If the judges elect not to use a game question, it must be replaced by another question so that the total number of questions to be asked will remain equal in each match.
9. At times, answers are given that are in agreement with the official reference books, which in fact are erroneous or out of date. Every effort is made to eliminate such questions; however, in the event that one slips in, the judges may agree to:
 - a. Accept the answer and give an explanation of the correct or updated information.
 - b. Accept only the correct answer.
 - c. Replace the question to the appropriate contestants.

TRANSCRIBING QUESTIONS

Transcribing contest questions by any means during the competition is prohibited. There will be no hand-written, typing, recording, computer use, etc. in the contest rooms. Affiliated teams will be eliminated from the competition for violation of this rule.

RECORDERS AND CAMERAS

Recording devices such as tape recorders, video cameras, picture movie cameras, cell phones etc. may not be used during competition. Copies of the game questions will be made available through your County Cooperative Extension office. State questions will be held in confidence to be available for the following years' Regional contests.

CELL PHONES

Cell phones must be turned OFF while in a contest room.

PHOTOGRAPHS

Photographs will be permitted only before or after a match and then in such a manner as not to be disruptive of the contest.

PROTESTS/VERIFICATION OF QUESTIONS AND/OR ANSWERS

1. Verification of a question and answer is permissible.
2. Only protests that are made in a courteous, respectful manner will be acknowledged.
3. A protest/verification of a question or the answer to a question may be called for by a **team captain, or the official team coach(es)**.
The judges, moderator and referee will consider the protest. Their **decision in all cases will be final**.
4. Protests must be made before reading the next question.
5. If the protest is acknowledged, play will be stopped and the designated officials will consider the protest and make a decision. A (minus 1 point penalty) will be assessed if the protest is not upheld.
6. To sustain a protest, the designated judges panel must agree to keep or replace a question or to determine the validity of an answer.
7. If the protest is sustained by the officials, the moderator and/or the scorekeepers will take one of the following actions:
 - a. If the question is determined by the officials to be a poor question, it will be replaced and opened to a specific chair on each team or to all contestants seated at the game table, depending on the type of questions (one-on-one or open).
 - b. If the answer to the question received a call for verification, the designated judges panel will determine the validity of the answer. Points will be awarded or deducted as appropriate.
 - c. If a question is protested after an answer is given, the designated judges panel will determine the validity of the protested question. If the validity of the question is allowed, points will be awarded or deducted as appropriate. If not, the question will be replaced.

8. All protests/challenges will be acknowledged by the contest staff.

ABUSE OF THE PROTEST PROVISIONS

1. In this competition, every effort will be made to be fair, courteous, and understanding to the contestants and the coaches.
2. Abuse of this protest provision by any contestant or coach will result in one or more of the following:
 - a. Dismissal of team coach from the contest area.
 - b. Dismissal (or replacement) of any contestant from the competition.
 - c. Dismissal of an entire team from the competition, with forfeiture of points or standings.
3. Spectators, Parents and Visitors
 - a. Spectators, parents and/or visitors **may not** protest any question, answer or procedure during the contest. They may, however, submit in writing to the contest officials any suggestions, complaints, or protests at the conclusion of the contest.
 - b. Any contestant, coach, family member, friend, or spectator exhibiting **unsportsmanlike conduct, behavior or actions detrimental to the contest, will be subjected to dismissal** from the immediate contest area.

GAME OFFICIALS

1. **Moderator (Quiz Person)** - The moderator shall assume the responsibility for reading questions and will acknowledge the chairs that are eligible to respond to one-on-one and open questions before the question is read. The moderator will accept all answers that are the same as/mean the same as the expected answer to the question. Any answer different from the expected answer will be referred to the judges panel, which will make the decision to accept or reject the given answer. Occasionally, the moderator may also be designated as part of the judge's panel.
2. **Judge's Panel** - The judge's panel will consist of one or more if possible. One will be a knowledgeable horse person. If possible, one will be a veterinarian.

It is especially important for the judges to explain their reason for not accepting an answer because the intent of this competition is to make it a unique learning experience for young people of high school grade levels. These young people have made a very strong commitment to this program, and above all, we want to be fair and honest with them. This is an excellent opportunity to further educate them along these lines. The judge's responsibility will be to rule jointly on the acceptability of any question or answer on all questions. In the event of a challenge to a question/answer, with 2 judges, either both judges or one judge and the moderator must agree on the acceptance or rejection of any question and/or answer. When there is only one judge, both the judge and the moderator or referee must agree on actions to be taken.

If an answer was not clearly heard, the contestant may be asked to repeat the answer. If a question is read to completion, and the answer given is different than the one expected, or if it is technically or logically correct, the answer may be accepted. If the answer given is “in the ball park”, the judge(s) may request the contestant to be more specific, expand, explain, or clarify the answer. If the question is interrupted, the judge(s) may not ask for any kind of clarification. The answer is either correct or incorrect according to the way the question was written.

All answers given must be correct for the way the question is written. An answer may be correct for a portion heard of a question that was interrupted, but wrong for the way the question was written. The judge(s) may not ask any questions, and the answer will be counted as a wrong answer. If the answer is correct for the way the question is written, it will be accepted.

All of the game questions will have a reference code, page number, and topic code. The required reference books will be available to look up information or for verification.

- 3. Time keeper - Control Operator** - The time keeper will monitor all time intervals and designate when the time of response has been exceeded and will handle all controls of the game equipment. It is strongly recommended that neither the moderator nor a judge be used as timekeeper. Since the timekeeper has controls that verify whose light is on, they could also become the acknowledger. It will also be their responsibility at the beginning of each match to assure each contestant that the equipment is working properly. The contestant is acknowledged when the acknowledger says the name of the youth (or team) buzzing in and the chair number that is responding. The contestant may not respond until they have been acknowledged. It will then be the responsibility of the Timekeeper or Moderator to verify whether or not a contestant has been acknowledged or if their time has run out.

Time Allowed:

To start a response to a question	5 seconds
To start answer after acknowledgment	5 seconds
For team to confer on a bonus question	10 seconds
For team to give answer to bonus question	30 seconds

- 4. Referee** - is responsible for all aspects of the game, will interpret the rules, and see that they are followed. The designated referee will also keep record in the question book of which team and which chair responded to a question in the event that there is an error in scoring. This record aids in reconstructing the proper score for the team as well as the individuals responding. The referee will chair all challenges and protests and will refer to the judges, moderator, scorekeepers for the best solution to problems. The judges panel and referee will have authority over questions and answers. The timekeeper and referee will have authority over all scoring procedures.
- 5. Scorekeepers** - At least two individuals shall be used to keep accurate team and individual scores. There will be visual scorekeepers recording the team score on a blackboard, overhead projector or flip chart as well as a paper copy for permanent records. Table score keeper(s) will keep a written record of the official team and individual scores. The visual scores will be set up so that they are visible to the table scorekeeper(s), the contestants, moderator and spectators, if possible. The written record of the scores must match the visual scores and will be the official records of all individuals

and team scores. A special score sheet will be available for the table scorekeeper(s), plus a special sheet for tabulating individual scores.

Scoring:

Correct answer -one-on-one questions	2 pts.
Correct answer - open questions	1 pt.
Toss-up questions - All answers required correct	1 pt.
Bonus questions - all required answers correct	3 pts.
Bonus questions - all incomplete answers/no answer	0 pts
Team participation bonus - all members at panel with correct answers	2 pts
All incorrect answers - toss-up/one-on-one	-1 pt.
Acknowledgment penalty- contestant not acknowledged	-1pt.
Response penalty-no answer started in 5 seconds/or out of turn	-2pts
Response penalty-out of turn 2 times eliminated from match	-2 pts.
Response penalty-out of turn 3 times eliminated from contest	-2 pts.
Official Protest not upheld	-1 pt.

EQUIPMENT

1. **Game Panels** - An appropriate device will be used to provide a clear indication of the first contestant to respond to a question.
2. **Time Recorders** - A stop watch, control panel timer or other appropriate timing device will be used.
3. **Signal Device** - This signal device shall be used by the timekeepers and shall have a distinctly different sound for each side or shall be a device that has a distinct sound and light that indicate which contestant is responding when a buzzer is activated. Back-up units will be available in the event of malfunction or failure.
4. **Scorekeeping Devices** - Two devices will be used. A blackboard, overhead projector, and/or a flip chart, as well as a paper copy, will be used to maintain team scores that are visible to the contestants and scorekeepers and , if possible, to the spectators. Special score sheets will be provided for keeping the written official individual and game scores for each match of the contest.

EQUIPMENT FAILURE

1. It shall be the responsibility of the acknowledger to assure each contestant that all equipment is operating correctly at the start of the match. Back-up units will be available.
2. If the device being used ceases to function during a match or is believed to be malfunctioning, a "time out" may be called by any contestant, the staff, or by either coach.

3. If after checking, it is determined that there is an equipment malfunction/failure, the faulty part(s) or unit will be replaced and play resumed.
4. Scores accumulated up to the point of the "time out" shall stand and all further points awarded during the remainder of the match added to or subtracted from this total.
5. If both judges or one judge and the referee or moderator deem it advisable, points awarded for the two(2) questions asked immediately prior to determination of the equipment failure may be recalled and two(2) additional questions used.
6. Under no conditions shall there be a replay of a match in which there was an equipment failure.

GAME OPTIONS

Round Robin - Each team in the contest is to play each other. Round Robin play is not recommended with more than six (6) teams. Procedure for Round Robin play is attached.

1. **Team Awards** - The rank of teams will be based on their win/loss record.
2. **Ties** - Teams with ties will be broken in the following priority:

First:	Head to head competition. (Which team won when tied teams played each other)
Second:	Total points earned in contest.
Third:	High Team match in contest.
3. **Individual Awards** - Top ten(10) individuals will be awarded on the following order of procedure:

First:	Total points earned in contest.
Second:	High individual match score. (Highest score in one match.)
Third:	Least number of wrong answers in matches played

Double Elimination

1. A double elimination bracket will be set up according to the number of teams competing. Variations of this bracket are enclosed within these rules.
2. Winners in the top bracket will remain in that bracket. Losing teams will proceed to the bottom bracket. All teams will continue playing until they have lost two(2) games. A special consolation game will be set up so that each team will have played three (3) games, thus making all contestants eligible for individual awards.
3. A total of two losses in the contest will automatically eliminate a team from the remaining competition. All winning teams will advance to the next round until there are four teams remaining in the competition. The teams remaining in the contest shall have no more than one loss.
4. The final round of the contest will be played between the winner of the top bracket

and the winner of the bottom bracket. Another game will be played in the event that both teams have a one-loss status.

Example: The winner of the top bracket has no losses and plays the winner of the bottom bracket that has one loss. The bottom bracket team wins the match, thus giving each team one loss. Another game must be played to give one team two losses, thus eliminating them from the competition.

Team Awards:

1. The rank of teams will be determined on the basis of their position within the double elimination brackets. To place teams eliminated in the same rounds in the bottom bracket, the team with the highest score will take the higher rank, the second high scoring team will take the next highest place and so on. Ties will be broken as follows:

First: High team average for entire contest. (Score divided by games.)
Second: High team match score. (Highest score for any one match.)
Third: Total number of team points earned in the contest.

Individual Awards

1. Scores will be kept for each individual contestant. Special recognition will go to top ten high scoring individuals.
2. Only those contestants who have participated in three or more matches will be considered for the top ten individual awards. The **high three (3) match scores** for each individual will be used in cases where individuals have competed in more than three matches.
3. **Ties** for individual awards will be broken as follows:

First: High individual average for entire contest.
Second: High individual match score. (highest score in one match.)
Third: Total number of individual points earned in the contest.

Combination Double Elimination/Round Robin (new option '94 National Play)

1. Double elimination procedure will be played until there are 4 remaining teams with no losses or one loss.
2. The four remaining teams will play a four team round-robin procedure, where each team will play the other three teams. Team scores earned in previous games, will be dropped and each team will start with a zero score (Previous individual and team scores will be used when evaluating awards).

Team Placings

1. The winning team will be based on **win/loss record in Round Robin**. Remaining teams will be placed as in Double Elimination Play. See Tie Breakers in Double Elimination for procedures. Ties for Round Robin Play will be broken in the following manner:

First: Head to Head competition in Round Robin.
Second: Total points for Round Robin.
Third: High team match for Round Robin.

Individual Placings

1. Top ten individuals will be recognized for individual awards. The **high three individual match scores for entire contest** for each individual will be used in cases where individuals have competed in more than three matches. Only those who have competed in three or more matches will be considered for top individual awards.
2. **Ties** will be broken in the following priority order:

First: High individual average for entire contest.
Second: High individual match score.
Third: Total number of individual points earned in entire contest.

SUGGESTED ROOM SET-UP

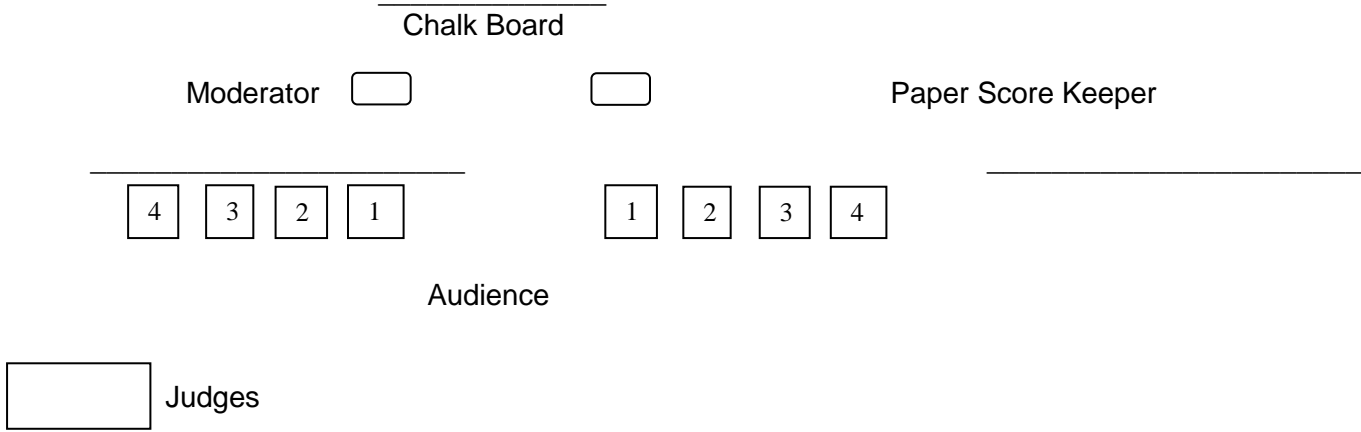

OR

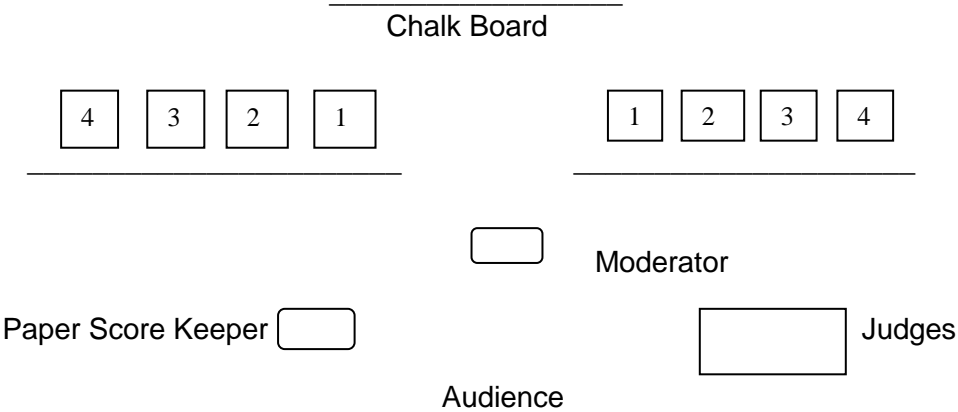

**Recommended Procedure for Round Robin Competition
4-H Horse Bowl Contest**

3 Teams – One room – 3 regular questions plus 1 set of tie breaker questions – isolation room required

Period I	1 vs 2	
Period II	2 vs 3	
Period III	1 vs 3	Approximate time: 15 minute matches, 1hr.

4 Teams – One or two rooms – 3 regular questions packets plus 1 set of tie breaker questions

Alternative A – one room – isolation room required

Period I	1 vs 2		
Period II	3 vs 4	} same questions (PK1)	
Period III	1 vs 3		
Period IV	2 vs 4	} same questions (PK2)	
Period V	1 vs 4		
Period VI	2 vs 3	} same questions (PK3)	Approximate time: 15 minute matches, 1 ¼ - 2hrs

Alternative B – two rooms – same questions used in both rooms

	Room A	Room B	
Period I	1 vs 2 (PK1)	3 vs 4 (PK1)	
Period II	2 vs 4 (PK2)	1 vs 3 (PK2)	
Period III	1 vs 4 (PK3)	2 vs 3 (PK3)	Approximate time: 15 minutes matches, 1 – 1 ¼ hrs

5 Teams – On or two rooms – 5 regular question packets plus 1 set of tie breaker questions

Alternative A – one room – isolation room required

Period I	2 vs 3 (PK1)	
Period II	4 vs 5 (PK)	
Period III	1 vs 2 (PK2)	
Period IV	3 vs 4 (PK2)	
Period V	1 vs 5 (PK3)	
Period VI	2 vs 4 (PK3)	
Period VII	1 vs 3 (PK4)	
Period VIII	2 vs 5 (PK4)	
Period IX	1 vs 4 (PK5)	
Period X	3 vs 5 (PK5)	Approximate time: 15 minute matches, 3-3 ½ hrs

Alternative B – two rooms (careful timing mandatory)

	Room A	Room B	
Period I	2 vs 3 (PK1)	-----	
Period II	4 vs 5 (PK1)	1 vs 2 (PK2)	
Period III	1 vs 5 (PK3)	3 vs 4 (PK2)	
Period IV	2 vs 4 (PK3)	1 vs 3 (PK4)	
Period V	1 vs 4 (PK5)	2 vs 5 (PK4)	
Period VI	3 vs 5 (PK5)		Approximate time: 15 minute matches, 2 – 2 ¼ hrs

6 Teams - Two rooms required - 5 regular question packets plus 1 set of tie breaker questions
 - Isolation room required

	Room A	Room B	
Period I	- 1 vs 2	4 vs 6	
Period II	- 3 vs 4 } (PK1)	2 vs 5 } (PK2)	
Period III	- 5 vs 6	1 vs 3	Period IX could be held in
Period IV	- 1 vs 4	2 vs 3	Room B - requires extracopy of PK5
Period V	- 3 vs 5 } (PK3)	1 vs 6 } (PK4)	
Period VI	- 2 vs 6	4 vs 5	
Period VII	- 1 vs 5		
Period VIII	- 2 vs 4 } (PK5)		Approximate time:
Period IX	- 3 vs 6		15 minute matches, 2-3/4-3 hours.

7 Teams - Two rooms required - 7 regular question packets plus 1 set of tie breaker questions
 - isolation room required

	Room A	Room B	
Period I	- 2 vs 3 (PK1)	1 vs 7 (PK2)	
Period 11	- 4 vs 5 (PK1)	3 vs 6 (PK2)	
Period 111	- 6 vs 7 (PK1)	2 vs 5 (PK2)	
Period IV	- 4 vs 6 (PK3)	3 vs 5 (PK4)	Period XII could be held in
Period V	- 1 vs 3 (PK3)	2 vs 6 (PK4)	Room B - requires extra copy
Period VI	- 5 vs 7 (PK3)	1 vs 4 (PK4)	of PK7
Period VII	- 1 vs 2 (PK5)	3 vs 4 (PK6)	
Period VIII	- 4 vs 7 (PK5)	1 vs 6 (PK6)	
Period IX	- 5 vs 6 (PK5)	2 vs 7 (PK6)	
Period X	- 1 vs 5 (PK7)		Approximate time:
Period XI	- 2 vs 4 (PK7)		15 minute matches, 4-4-1/4 hours
Period XII	- 3 vs 7 (PK7)		

8 Teams - At least two rooms required plus isolation room
 - 7 regular question packets plus 1 set of tie breaker questions -

Alternative A - two rooms

	Room A	Room B	
Period I	- 1 vs 2 (PK1)	4 vs 5 (PK2)	
Period II	- 3 vs 4 (PK1)	2 vs 7 (PK2)	
Period III	- 5 vs 6 (PK1)	3 vs 8 (PK2)	
Period IV	- 7 vs 8 (PK1)	1 vs 6 (PK2)	
Period V	- 1 vs 3 (PK3)	2 vs 6 (PK4)	
Period VI	- 2 vs 4 (PK3)	1 vs 5 (PK4)	
Period VII	- 5 vs 7 (PK3)	4 vs 8 (PK4)	Periods XV and XVI could be
Period VIII	- 6 vs 8 (PK3)	3 vs 7 (PK4)	Held in Room B - requires
Period IX	- 1 vs 4 (PK5)	2 vs 8 (PK6)	Extra copy of PK7
Period X	- 2 vs 3 (PK5)	1 vs 7 (PK6)	
Period XI	- 6 vs 7 (PK5)	3 vs 5 (PK6)	
Period XII	- 5 vs 8 (PK5)	4 vs 6 (PK6)	
Period XIII	- 1 vs 8 (PK7)		
Period XIV	- 2 vs 5 (PK7)		
Period XV	- 3 vs 6 (PK7)		
Period XVI	- 4 vs 7 (PK7)		

8 Teams-

Alternative B - three rooms

	Room A	Room B	Room C
Period I	- 1 vs 2 (PK1)	4 VS 5 (PK2)	3 vs 6 (PK3)
Period II	- 3 vs 4 (PK1)	2 vs 7 (PK2)	1 vs 8 (PK3)
Period III	- 5 vs 6 (PK1)	3 vs 8 (PK2)	4 vs 7 (PK3)
Period IV	- 7 vs 8 (PK1)	1 vs 6 (PK2)	2 vs 5 (PK3)
Period V	- 1 vs 3 (PK4)	2 vs 6 (PK5)	5 vs 8 (PK6)
Period VI	- 2 vs 4 (PK4)	1 vs 5 (PK5)	6 vs 7 (PK6)
Period VII	- 5 vs 7 (PK4)	4 vs 8 (PK5)	2 vs 3 (PK6)
Period VIII	- 6 vs 8 (PK4)	3 vs 7 (PK5)	1 vs 4 (PK6)
Period IX	- 2 vs 8 (PK7)	1 vs 7 (PK7)	3 vs 5 (PK7)
Period X	- 4 vs 6 (PK7)		

Approximate time:
15 minute matches, 3 hours

Alternative C - four rooms

	Room A	Room B	Room C	Room D
Period I	- 1 vs 2	3 vs 4	5vs6	7vs8(PK1)
Period II	- 6 vs 8	5 vs 7	1 vs 3	2 vs 4 (PK2)
Period III	- 2 vs 7	1 vs 6	3vs8	4vs5(PK3)
Period IV	- 1 vs 5	2 vs 6	4 vs 8	3 vs 7 (PK4)
Period V	- 5 vs 8	1 vs 4	6 vs 7	2 vs 3 (PK5)
Period VI	- 3 vs 5	2 vs 8	1 vs 7	4 vs 6 (PK5)
Period VII	- 4 vs 7	3 vs 6	2 vs 5	1 vs 8 (PK7)

Approximate time:
15 minute matches, 2-2-1/4 hours

PLEASE NOTE: Round Robin play with **more than six (6)** teams is not recommended.

DOUBLE ELIMINATION - 8 TEAMS
GAME SCHEDULE

	Room A	Room B
Round I	1 3	2 4
Round II	5 7	6 8
Round III	9 11	10 11 B (consolation)'
Round IV	13	
Round V	16	
Round VI	17	
Round VII (if needed)"	18	

" Consolation game so every team plays 3 matches.

** If team from bottom bracket wins, top bracket team would have only one loss. Another game must be played to give one team two losses.

Round I Round II Round III Round IV Round V Round VI

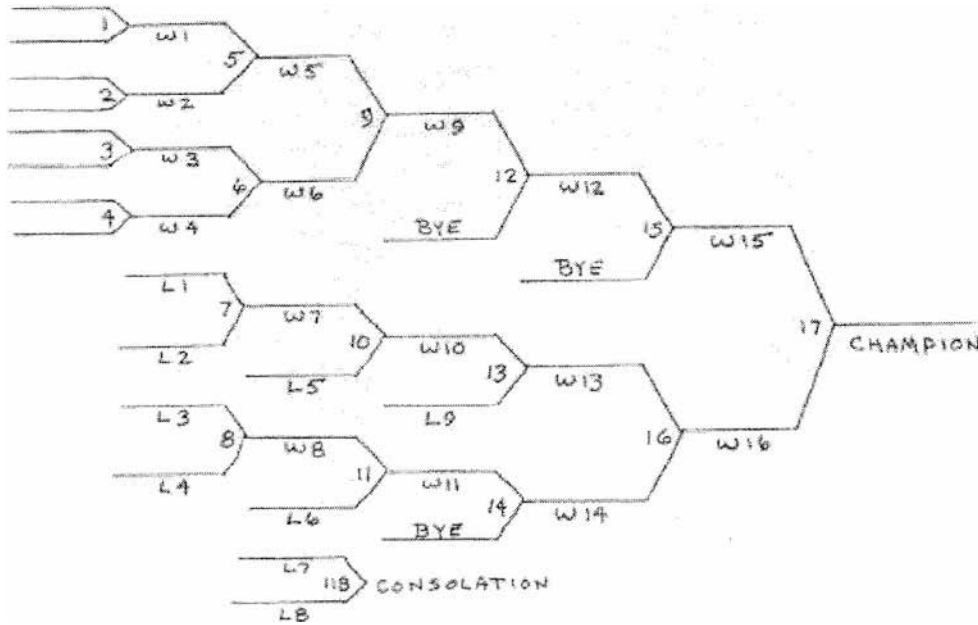

DOUBLE ELIMINATION/ROUND ROBIN- 8 TEAMS

SCHEDULE

	Room A	Room B
Round I	1 3	2 4
Round II	5 7	6 8
Round III	9 11*	10
Round IV	W-5 W-6	W-9 W-10
Round V	W-5 W-9	W-6 W-10
Round VI	W-5 W-10	W-9 W-6

* Consolation game 90 e vsry team plays 3 matches.

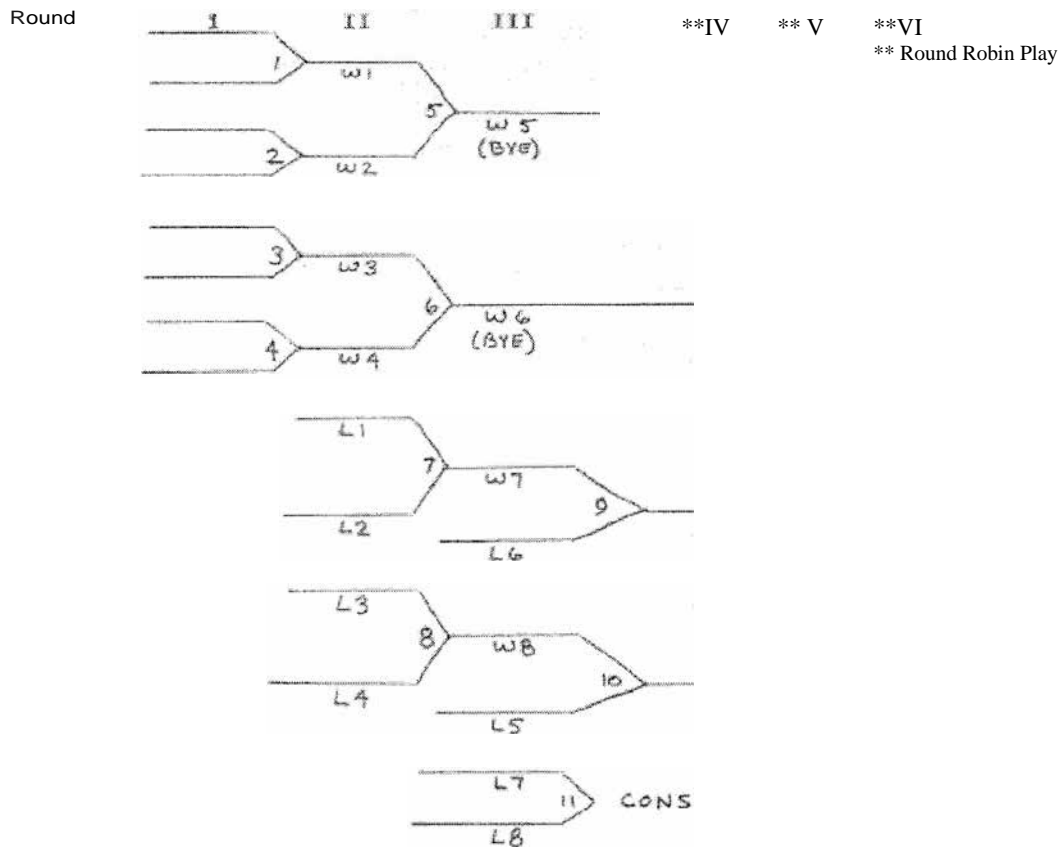

1.

II-22

**DOUBLE ELIMINATION - 9 TEAMS
SCHEDULE**

	Room A	Room B
Round I	1 4	3 5
Round II	6 8	7 9
Round III	10 12	11 12B*
Round IV	13	14
Round V		15
Round VI	16	
Round VII	17	
Round VIII** if needed		

*Consolation game so every team plays 3 matches.

** If team from bottom bracket wins, top bracket team would have only one loss. Another game must be played to give one team two losses.

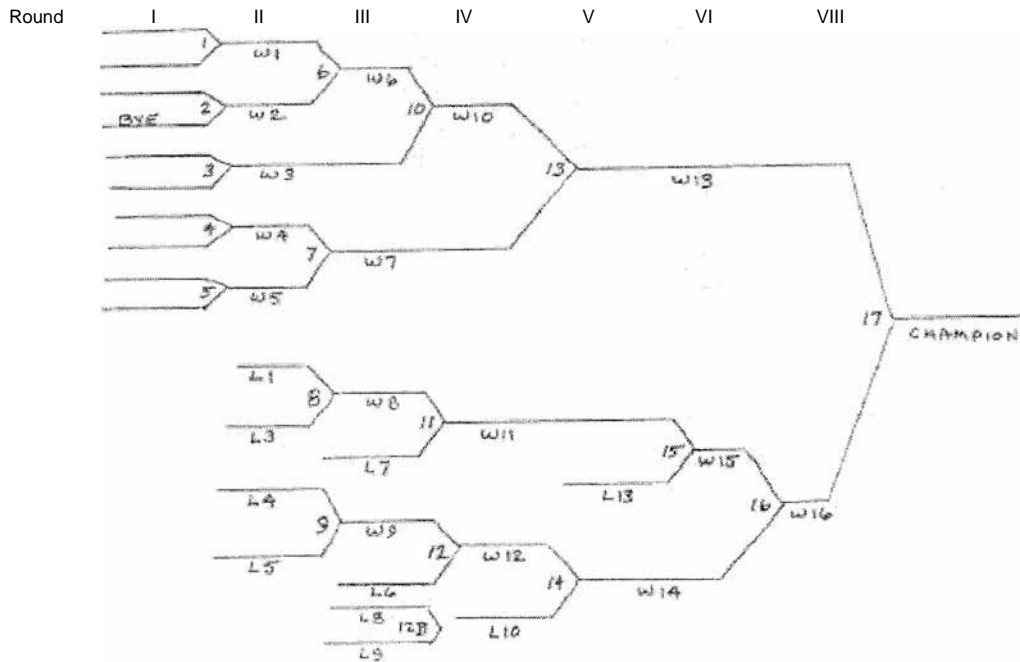

DOUBLE ELIMINATION/ROUND ROBIN - 9

TEAMS SCHEDULE

	Room A	Room B
Round I	1 4	3 5
Round /I	6 8	7 9
Round III	10 12	11 12b*
Round IV	13	14
Round V	W-13 W-11	L-13 W-14
Round VI	W-13 L-13	W-14 W-11
Round VII	W-13 W-14	W-11 L-13

* Consolation game so every team plays three matches.

Round I II III IV **V **VI **VIII
**Round Robin Play

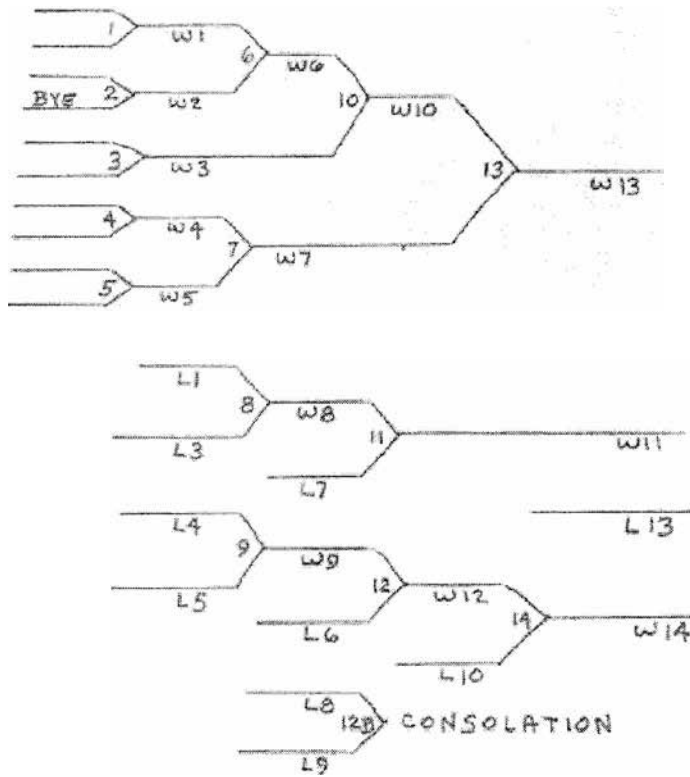

DOUBLE ELIMINATION - 10 TEAMS
GAME SCHEDULE

	Room A	Room B	Room C
Round I	1 4	2 5	3
Round /I	7	8	6 9
Round 11/	10	11	12
Round IV	13	14	15
Round V	16	Consolation game	Consolation game
Round VI	17		
Round VII	18		

Round I II III IV V VI VII VIII*

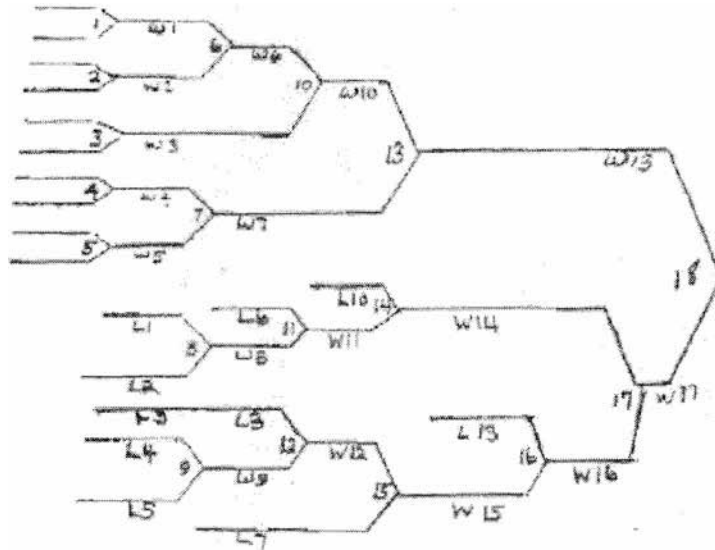

*if needed

DOUBLE ELIMINATION/ROUND ROBIN -10 TEAMS

GAME SCHEDULE

	Room A	Room B	Room C
Round 1	1 4	2 5	3
Round 2	7	8	6 9
Round 3	10	11	12
Round 4		13	14
Round 5	W10 W7	W13 W14	'Consolation games as needed
Round 6'	W10 W13	W7 W14	
Round 7 *	W10 W14	W13 L7	

Round I II III IV *V *VI *VII

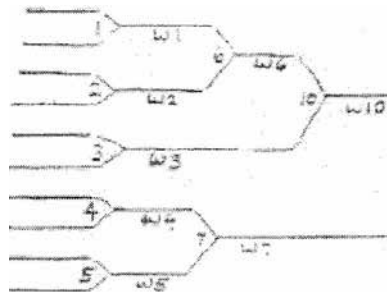

*Round Robin Play

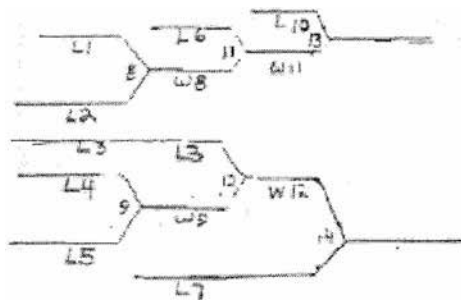

DOUBLE ELIMINATION -11 TEAMS
GAME SCHEDULE

	Room A	Room B	Room C
Round 1	1 4	2 5	3
Round 2	7 10	8	6 9
Round 3	11 14	12 15	13
Round 4	16	17	18
Round 5	19	W13 W14	
Round 6	20	W7 W14	
Round 7 *	21	W13 L7	

Round 2. II III IV V VI VII VIII *if needed

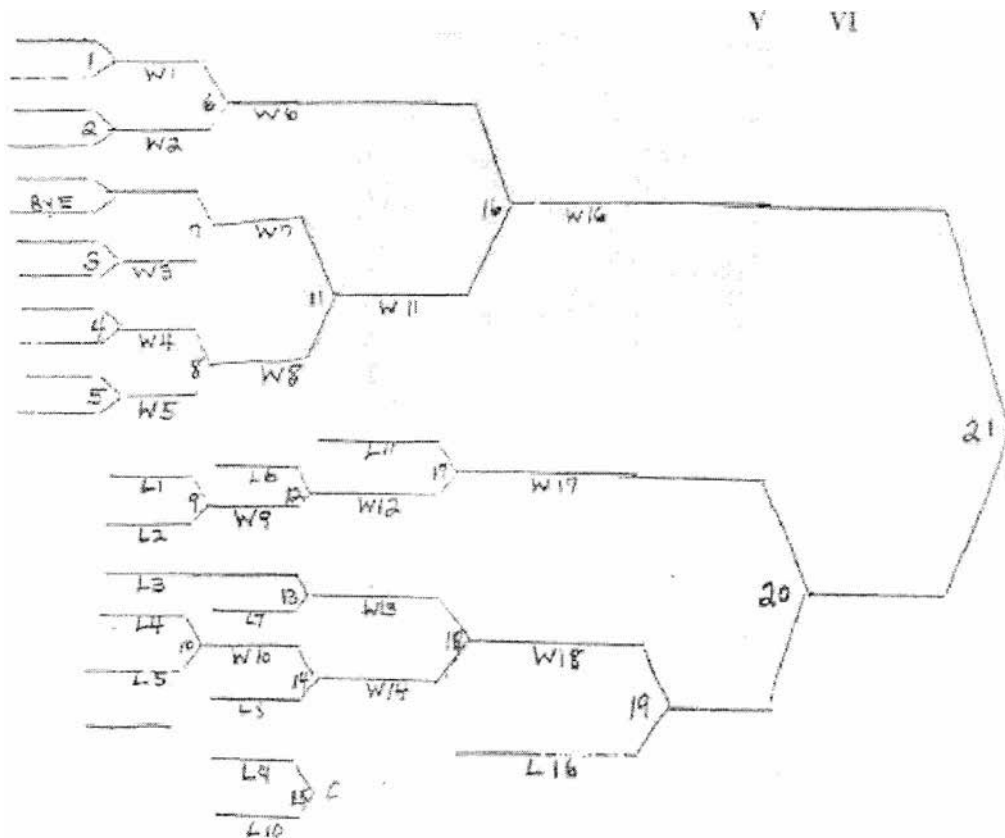

**DOUBLE ELIMINATION/ROUND ROBIN -11 TEAMS
GAME SCHEDULE**

	Room A	Room B	Room C
Round I	1 4	2 5	3
Round II	7 10	8	6 9
Round III	13	11 14	12 15
Round IV	16	17	18
Round V	W16 W17	W18 W16	
Round VI	W16 W18	W17 W16	
Round VII	W16 L16	W18 W17	

Round I II III IV *V *VI *VII
 *Round Robin

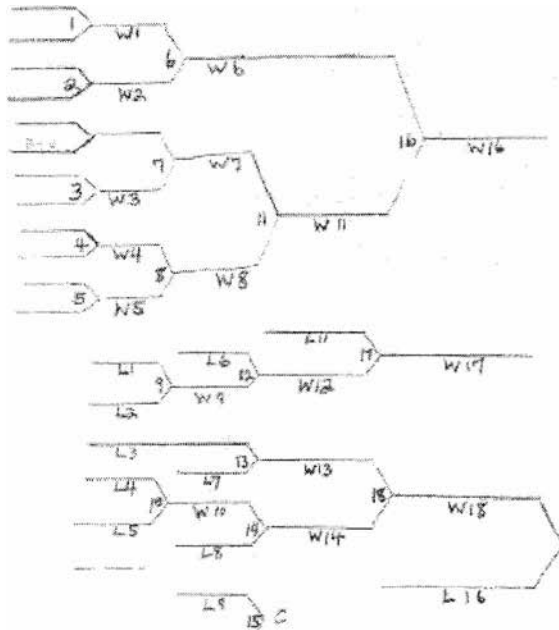

DOUBLE ELIMINATION -12 TEAMS
GAME SCHEDULE

	Room A	Room B	Room C
Round 1	1 4	2 5	3 6
Round 2	7 10	8 11	9 12
Round 3	13 16	14 17*	15
Round 4	19	20	18 21*
Round 5	22	W18	
Round 6	23	W17	
Round 7	24	W18	
Round 8	25(if needed)	*Consolation game	

3.

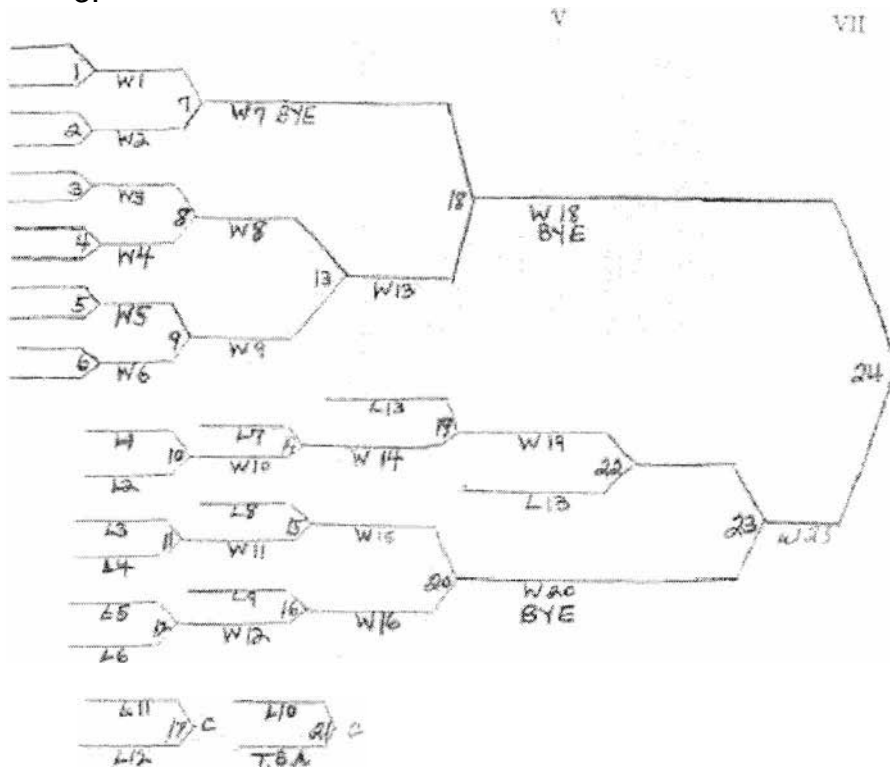

Double Elimination/Round Robin – 12 Teams II-29
 Schedule

	Room A	Room B	Room C
Round 1	1 4	2 5	3 6
Round 2	7 10	8 11	9 12
Round 3	13 16	14 17** Consolidation game	15
Round 4	19	20	18
Round 5	W 18 W 19	L18 W 20	
Round 6 *	W 18 L18	W 19 W 20	
Round 7*	W 18 W 20	W19 L18	

