

DOUBLE ELIMINATION - 8 TEAMS
GAME SCHEDULE

	Room A	Room B
Round I	1 3	2 4
Round II	5 7	6 8
Round III	9 11	10 11B (consolation)*
Round IV	13	
Round V	16	
Round VI	17	
Round VII (if needed)**	18	

" Consolation game so every team plays 3 matches.

** If team from bottom bracket wins, top bracket team would have only one loss. Another game must be played to give one team two losses.

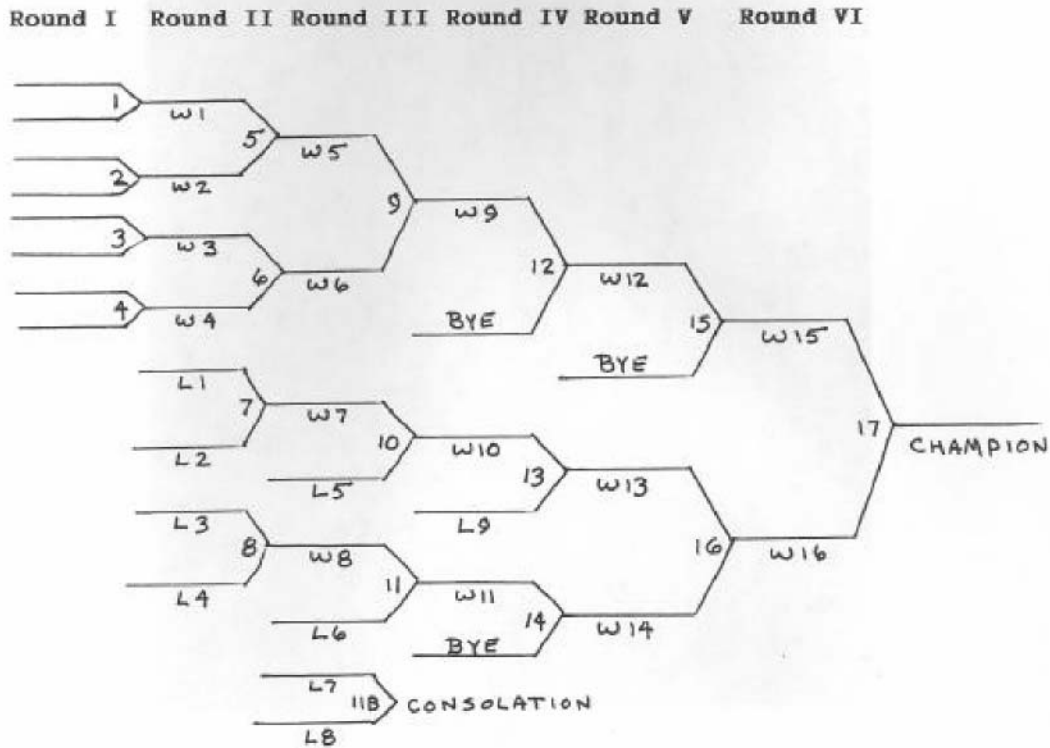

DOUBLE ELIMINATION/ROUND ROBIN - 8 TEAMS

SCHEDULE

	Room A	Room B
Round I	1 3	2 4
Round II	5 7	6 8
Round III	9 11*	10
Round IV	W-5 W-6	W-9 W-10
Round V	W-5 W-9	W-6 W-10
Round VI	W-5 W-10	W-9 W-6

* Consolation game 90 e vsry team plays 3 matches.

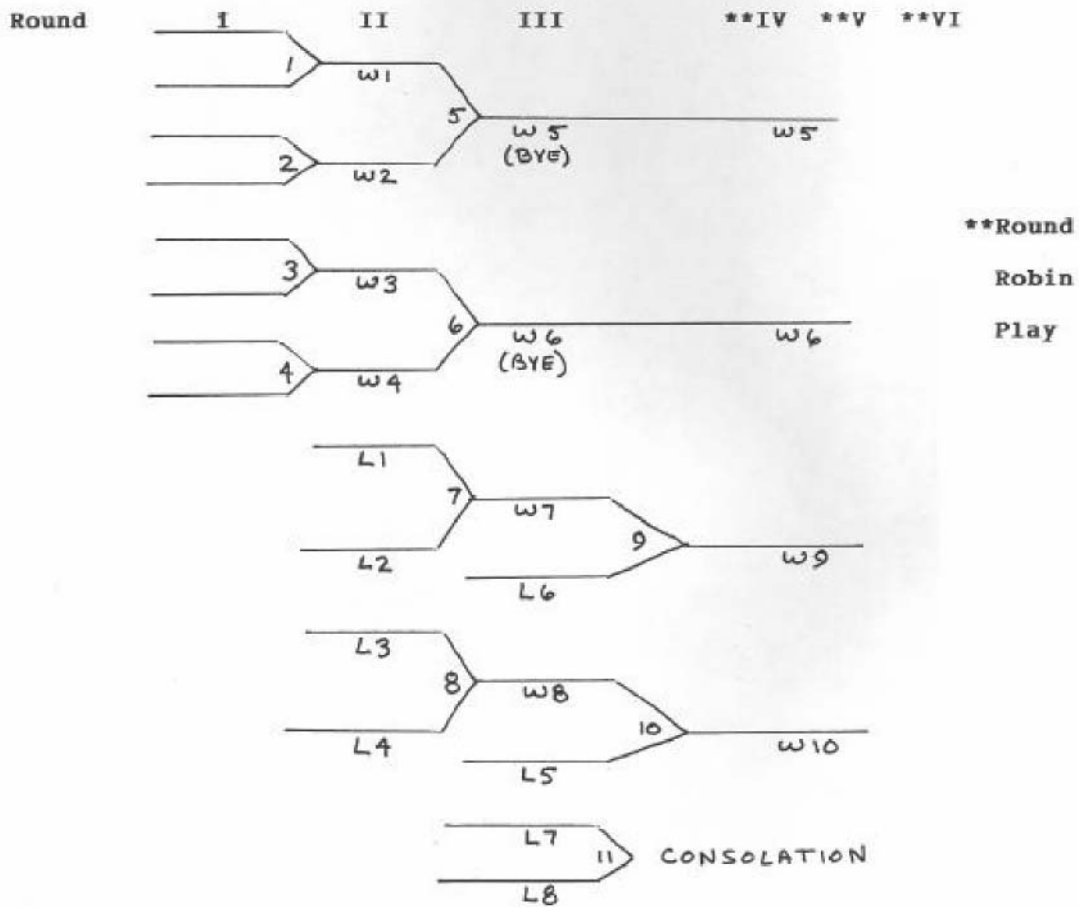

DOUBLE ELIMINATION - 9 TEAMS
SCHEDULE

	Room A	Room B
Round I	1 4	3 5
Round II	6 8	7 9
Round III	10 12	11 12B*
Round IV	13	14
Round V		15
Round VI	16	
Round VII	17	
Round VIII** if needed		

*Consolation game so every team plays 3 matches.

** If team from bottom bracket wins, top bracket team would have only one loss. Another game must be played to give one team two losses.

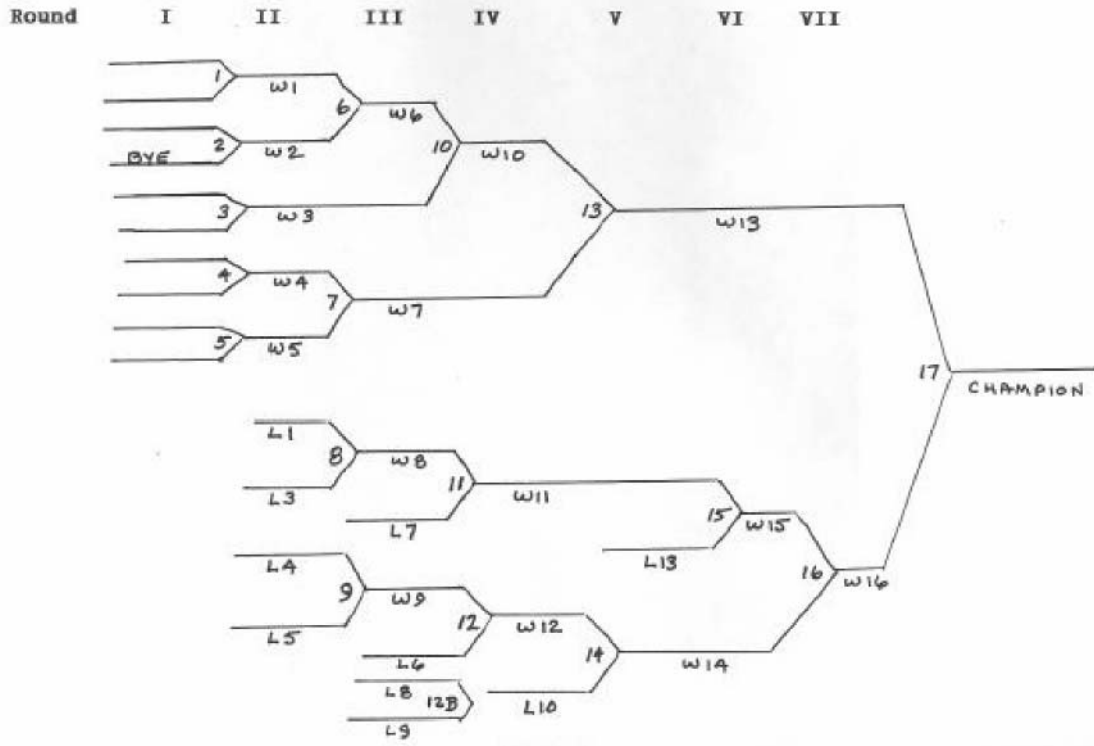

DOUBLE ELIMINATION/ROUND ROBIN - 9 TEAMS SCHEDULE

	Room A	Room B
Round I	1 4	3 5
Round II	6 8	7 9
Round III	10 12	11 12b*
Round IV	13	14
Round V	W-13 W-11	L-13 W-14
Round VI	W-13 L-13	W-14 W-11
Round VII	W-13 W-14	W-11 L-13

* Consolation game so every team plays three matches.

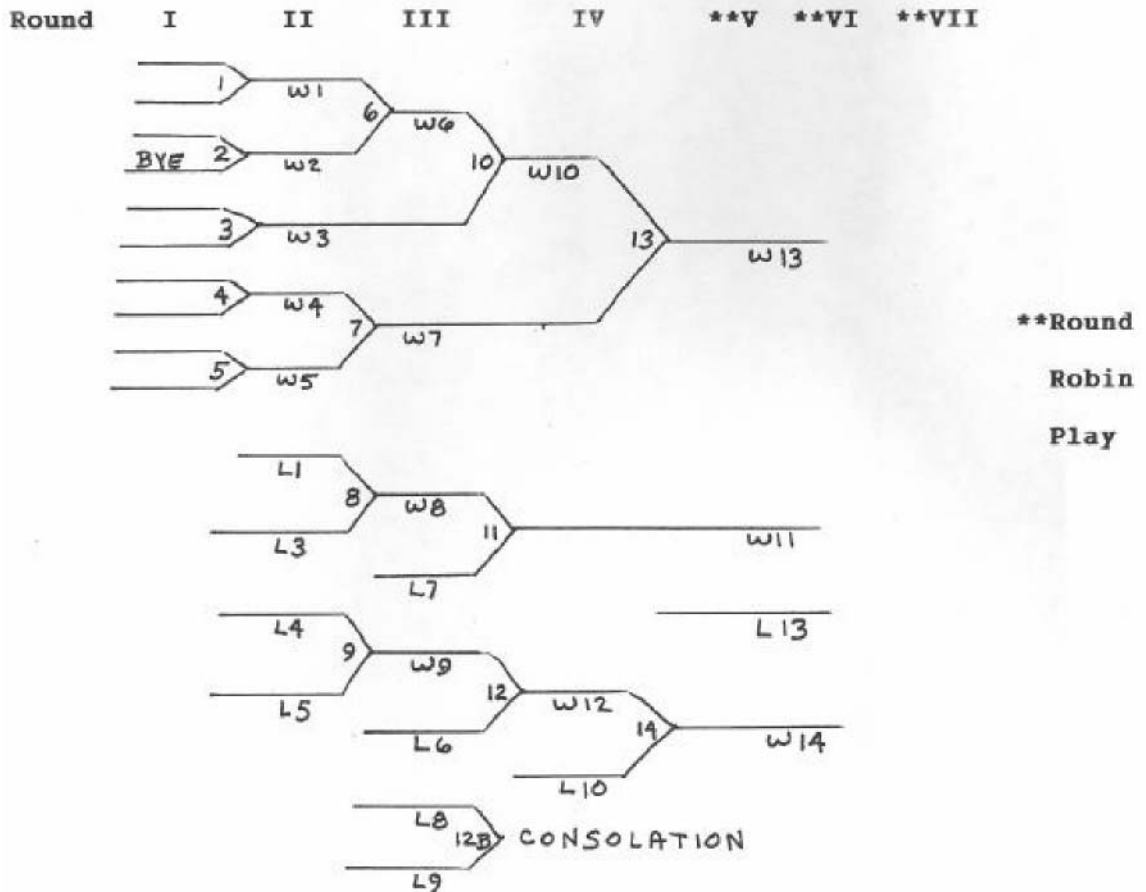

DOUBLE ELIMINATION - 10 TEAMS GAME SCHEDULE

	Room A	Room B	Room C
Round I	1 4	2 5	3
Round II	7	8	6 9
Round III	10	11	12
Round IV	13	14	15
Round V	16	Consolation game	Consolation game
Round VI	17		
Round VII	18		

Round I II III IV V VI VII VIII*
*if needed

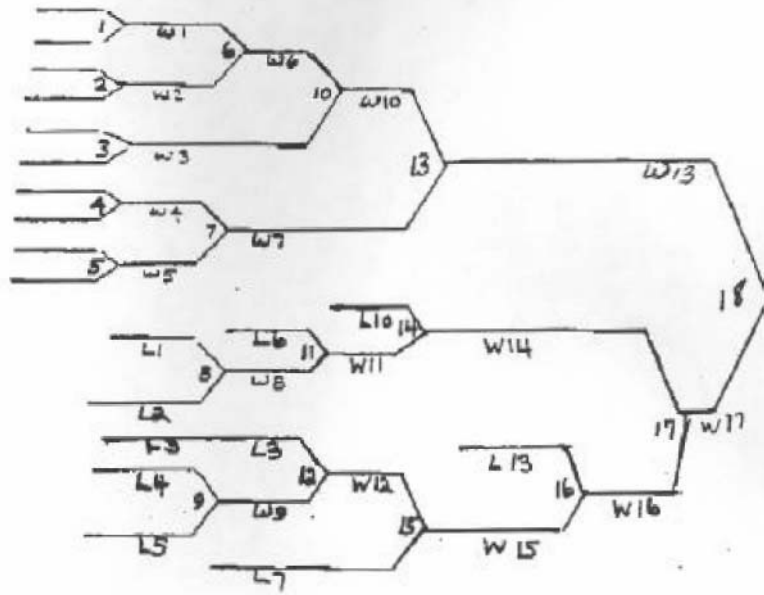

DOUBLE ELIMINATION/ROUND ROBIN - 10 TEAMS

GAME SCHEDULE

	Room A	Room B	Room C
Round 1	1 4	2 5	3
Round 2	7	8	6 9
Round 3	10	11	12
Round 4		13	14
Round 5	W10 W7	W13 W14	*Consolation games as needed
Round 6 *	W10 W13	W7 W14	
Round 7 *	W10 W14	W13 L7	

Round I II III IV V* VI* VII*

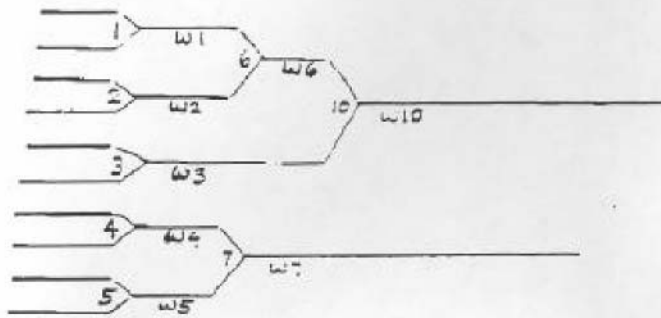

*Round Robin Play

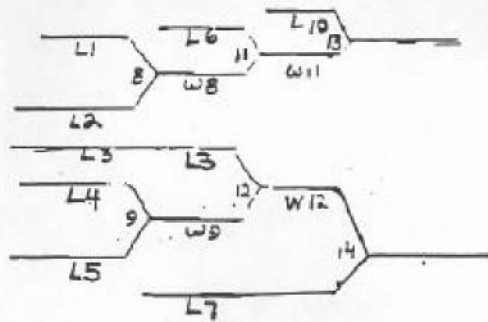

DOUBLE ELIMINATION - 11 TEAMS
GAME SCHEDULE

	Room A	Room B	Room C
Round 1	1 4	2 5	3
Round 2	7 10	8	6 9
Round 3	11 14	12 15	13
Round 4	16	17	18
Round 5	19	W13	
Round 6 *	20	W14 W7 W14	
Round 7 *	21	W13 L7	

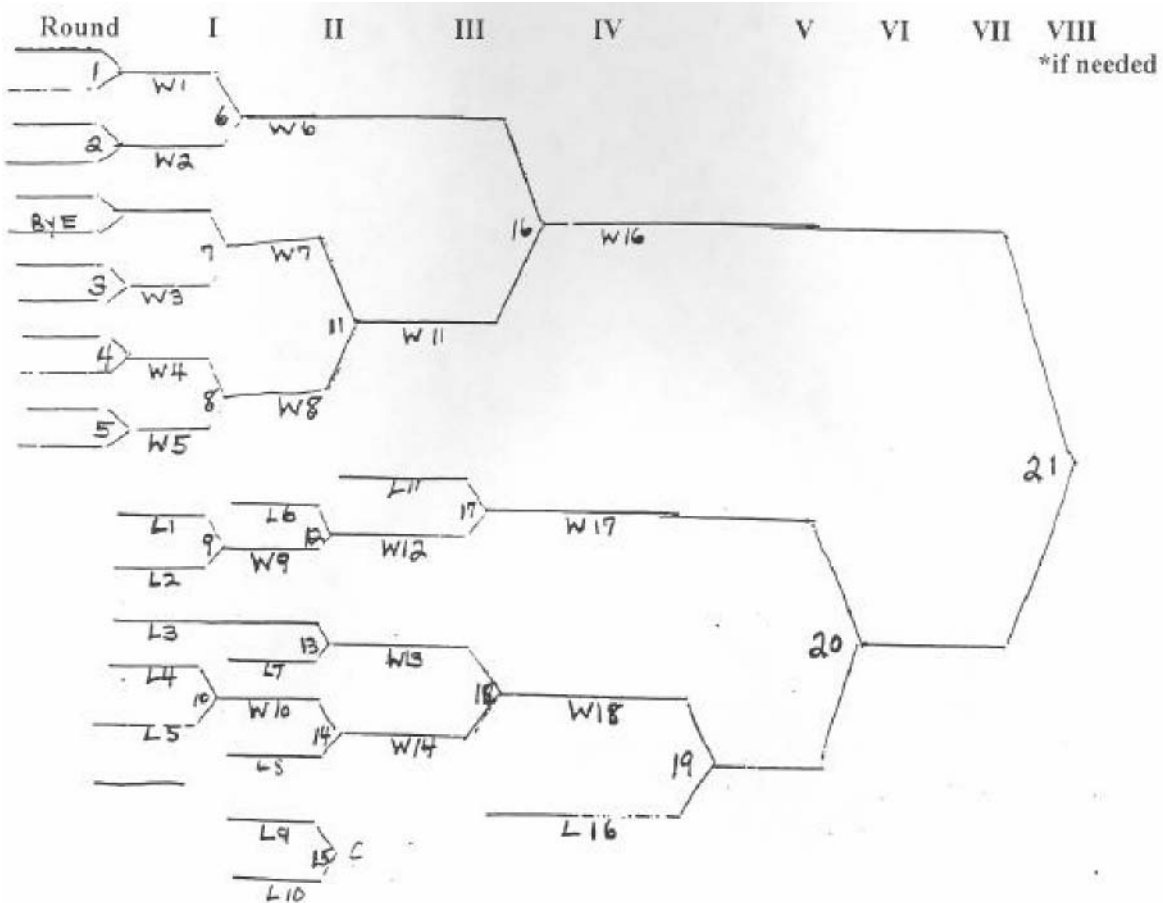

**DOUBLE ELIMINATION/ROUND ROBIN - 11 TEAMS
GAME SCHEDULE**

	Room A	Room B	Room C
Round I	1 4	2 5	3
Round II	7 10	8	6 9
Round III	13	11 14	12 15
Round IV	16	17	18
Round V	W16 W17	W18 W16	
Round VI	W16 W18	W17 W16	
Round VII	W16 L16	W18 W17	

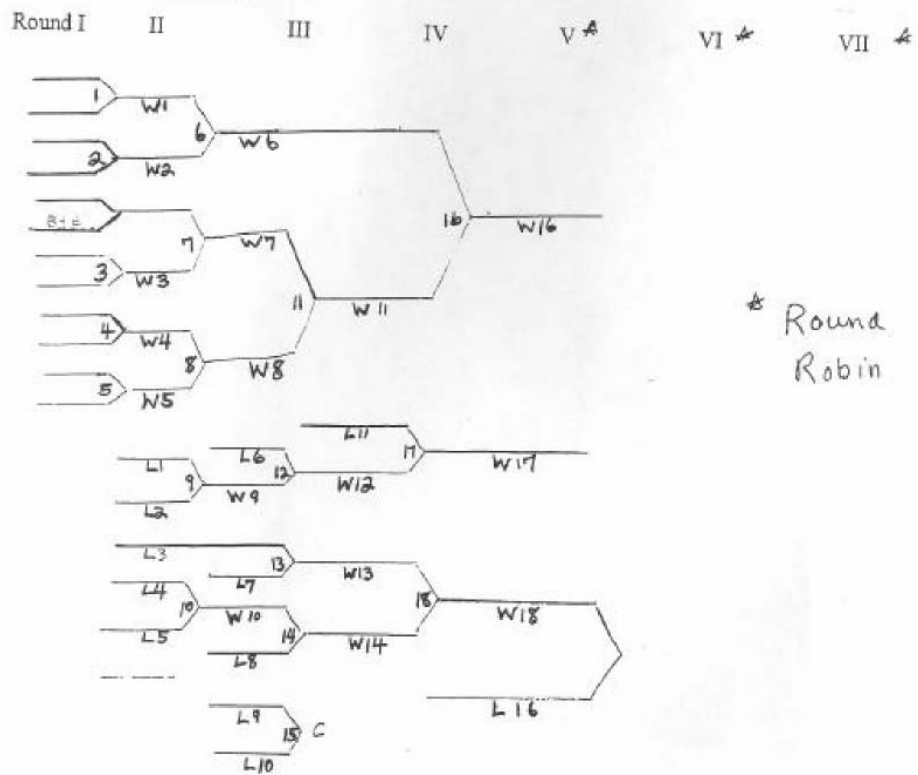

**DOUBLE ELIMINATION - 12 TEAMS
GAME SCHEDULE**

	Room A	Room B	Room C
Round 1	1 4	2 5	3 6
Round 2	7 10	8 11	9 12
Round 3	13 16	14 17*	15
Round 4	19	20	18 21*
Round 5	22	W18	
Round 6	23	W17	
Round 7	24	W18	
Round 8	25(if needed)	*Consolation game	

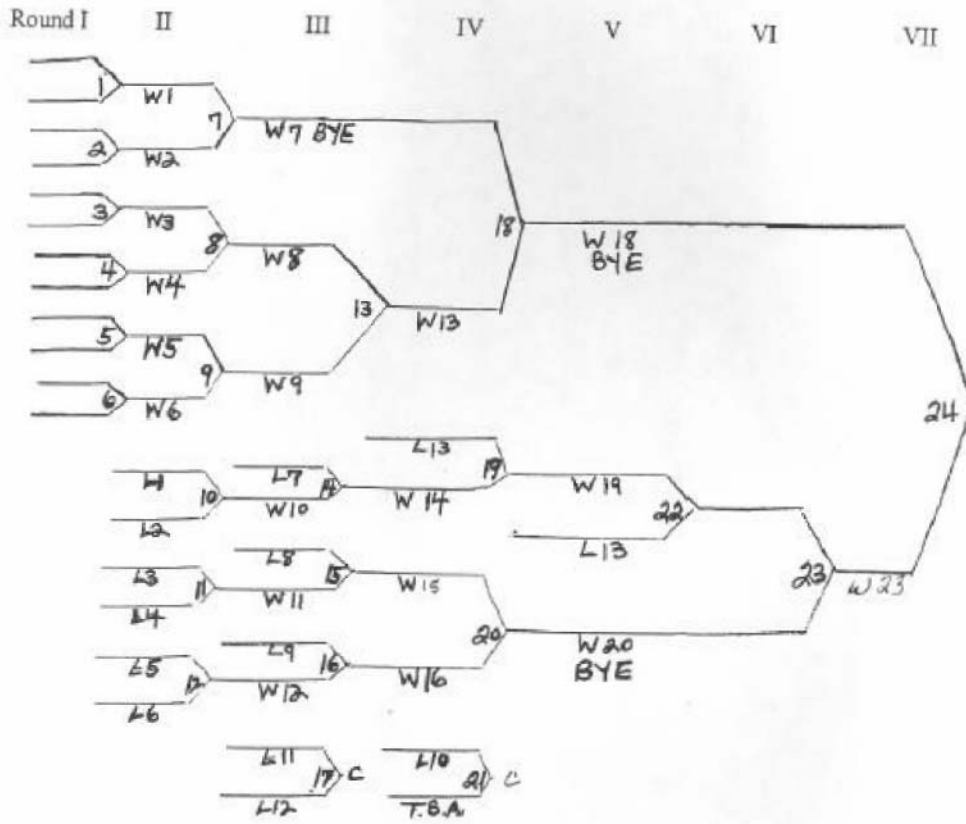

DOUBLE ELIMINATION/ROUND ROBIN - 12 TEAMS SCHEDULE

11-29 GAME

	Room A	Room B	Room C
Round 1	1 4	2 5	3 6
Round 2	7 10	8 11	9 2
Round 3	13 16	14 17**Consolation game	15
Round 4	19	20	18 21 **Consolation game
Round 5	W18 W19	L18 W20	
Round 6 *	W18 L18	W19 W20	
Round 7 *	W18 W20	W19 L18	

