

NEW YORK STATE 4-H WESTERN DIVISION

I. PERSONAL ATTIRE AND APPOINTMENTS

A. Required

1. Approved protective helmet
2. Long sleeved western shirt or short sleeved shirt with jacket
** shirts must have collars **
3. Western type boots with distinguishable heel
4. Western riding pants or denims

B. Optional

1. Western style tie
2. Vest - to be worn with long sleeved shirt only
3. Jacket
4. Chaps
5. Slicker or raincoat
6. Sweater
7. Gloves
8. Blunt rowelled or unrowelled spurs – must have strap
9. Standing martingales, running martingales and training forks will be allowed for warm-up and practice.

C. Prohibited

1. No t-shirts, sweatshirts or crew type necklines
2. Clip-on spurs

II. TACK AND EQUIPMENT

A. Required

1. Approved curb straps - 1/2" flat, single leather or chain
2. Western/stock type saddles (including barrel racing saddles, Australian stock saddles with or without a horn)
3. Western curb bit and bridle
4. Western style pad, fleece, Navaho blanket
5. Acceptable western style girth (If backstrap is used, a connector strap is required.)

B. Optional

1. Breast collars
2. Solid or jointed mouthpiece bits

C. Prohibited

1. Bit shank longer than 8-1/2"

2. English bits - (Except in Dressage classes - refer to Dressage rules)
3. Half breed bits
4. Swivel ports or flat polo mouthpieces
5. Roping bits
6. Spade bits
7. Hackamores and bosals - (Except for junior equines in bosals - refer to Western Division, section IV)
8. Cavessons and dropped nosebands
9. Whips, quirts, bats, etc.

D. Allowed in practice and warm-up rings

1. Tie downs and martingales
2. Draw reins, side reins, chambon, nose reins, gogue and similar training devices

PLEASE NOTE: If there is any doubt, talk with the Division Chairperson or Equine Show Superintendent. If a decision needs to be made, it will be made by the Equine Show Committee.

III. CLASS DESCRIPTIONS

JUNIOR EQUINES MAY BE SHOWN IN A SNAFFLE BIT, BOSAL OR HACKAMORE - Refer to Section IV.

A. Stock Seat Equitation - Only the rider is being judged, therefore any equine that is suitable for this style of riding and is capable of performing the required class routine is acceptable. The results as shown by the performance of the equine are not to be considered more important than the method used in obtaining them. The rider should present the appearance of being relaxed and comfortable, while at the same time being in complete control of the equine.

1. **Scoring** - Emphasis in the class will be placed on the rider's ability to effectively control the equine and maintain the basic position while doing so. To be judged on the rider's position, use of aids and cues, and control of the equine.
2. **Basic Position** - The rider should sit in the saddle with legs hanging straight forward to the stirrups, or with the knees slightly bent. Weight should be directly over the balls of the feet. In either position, the stirrups should be just short enough to allow the rider's heels to be lower than his toes. He should sit in the deepest part of the saddle and maintain this seat at all times.
3. **Hands and Arms** - Only one hand is to be used for reining. The hand chosen (either right or left) shall not be changed during the class. If a rope is carried on the saddle, it must be attached to the side opposite the reining hand. One finger is allowed between the reins except when romal reins are used. The rider may hold the romal or ends of the split reins provided it is held at least 16" from the reining hand.

The reining arm should be bent at the elbow with the hand being held slightly above and in front of the horn. The position of the hand not being used for reining is optional, but it should be kept free of the equine and equipment. It should be held in a relaxed manner, close to the rider's body or leg at all times.

4. **Position in the Saddle** - The rider should sit to jog and **not post**. At the lope, he should be close to the saddle. All movements of the equine should be governed by the use of imperceptible aids and the shifting of the rider's weight or leaning in either direction to obtain the proper lead is not desirable.

5. **Class Routine**

- a) All contestants will enter the ring at the walk in a counterclockwise direction until otherwise directed by the judge. They shall then go at least once around the ring at each of the three gaits - walk, jog and lope. They shall then be reversed and repeat the same procedure in the other direction. The reverse may be done by turning away from or toward the rail. Entries will then be lined up for close inspection and each exhibitor asked to back his or her equine 3 to 5 steps in a straight line.
- b) After all equines have been worked as specified in above, the judge may then dismiss any not to be further considered in the class.
- c) The judge may continue to work the remaining entrants at the walk, jog and lope as before, or he may ask any of the riders to execute an appropriate test of their riding skills. Suggested tests from which the judge might choose include:
 - 1) Back in a straight line at least 15'.
 - 2) Figure 8 at the jog.
 - 3) Lope and stop.
 - 4) Figure 8 at the lope, demonstrating simple change of leads.
 - 5) Ride without stirrups.
 - 6) Change of leads down the center of the ring, demonstrating a simple change of leads.
 - 7) Extend the jog **while sitting in saddle** and maintaining basic position - extreme speed will be penalized.
 - 8) Execute 360 degree turns.
 - 9) Ride serpentine course, demonstrating flying changes of lead at each change of direction.
 - 10) Any combinations of the above or others at the discretion of the judge.

B. Western Pleasure - A good pleasure equine has a stride of reasonable length in keeping with his conformation. He has enough cushion to his pastern to give the rider a pleasant, smooth ride. He carries his head in a natural position, not high and over flexed at the poll or low with the nose out. The equine should be relaxed but alert and ready to respond to the rider's commands without excessive cueing. When asked to extend the jog, he moves out with the same smooth way of going.

1. **Scoring** - Emphasis in this class will be placed on the equine's suitability as a pleasure mount as evidenced by both the performance in the class and its general type, conformation, and soundness. Scoring will be based on performance and on conformation.

2. **Class Routine**

a) Gaits

- 1) The walk is a natural, flat-footed four-beat gait. The equine must move straight and true at the walk. The walk must be alert, with a stride of reasonable length in keeping with the size of the equine.
- 2) The jog is a smooth ground-covering two-beat diagonal gait. The equine works from one pair of diagonals to the other pair. The jog should be square, balanced and with a straight, forward movement of the feet. Equines walking with their back feet and trotting on the front are not considered performing the required gait.
- 3) The lope is an easy, rhythmical three-beat gait. Equines moving to the left should lope on the left lead. Equines moving to the right should lope on the right lead. Equines travelling at a four-beat gait are not considered to be performing at a proper lope. The equine should lope with a natural stride and appear relaxed and smooth. He should be ridden at a speed that is natural in way of going.

b) All equines will enter the ring in a counterclockwise direction at the walk until they are otherwise directed by the judge. They will then go at least once around the entire ring at each of the three gaits - walk, jog and lope. All equines will then be asked to reverse and work the same way in that direction. The reverse shall be done by turning away from the rail.

c) After all equines have been worked, the judge may then excuse equines not to be considered further in the class.

d) The judge may ask for additional work from any of the remaining equines.

e) All equines being considered for an award shall be asked to back in a straight line a minimum of 3 steps.

f) Only one hand is to be used for reining. The hand chosen (either right or left) shall not be changed during the class. If a rope is carried on the saddle, it must be attached to the side opposite the reining hand. One finger is allowed between the reins except when romal reins are used. The rider may hold the romal or ends of the split reins provided it is held at least 16" from the reining hand.

C. **Western Riding** - This class is a competition in the performance of a sensible, well mannered, free and easy moving ranch equine, which can get its rider around on the usual ranch chores, over the trails, and will give a quiet, comfortable and pleasant ride in open country over obstacles. Special emphasis shall be given to the rider's methods used in obtaining the equine's performance.

1. **Pattern**

1. Walk & jog over log
2. Transition to lope & lope around end
3. First line change
4. Second line change
5. Third line change
6. Fourth line change & lope around end of arena
7. First crossing change
8. Second crossing change
9. Lope over log
10. Third crossing change
11. Fourth crossing change
12. Lope up the center, stop & back

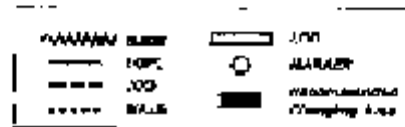
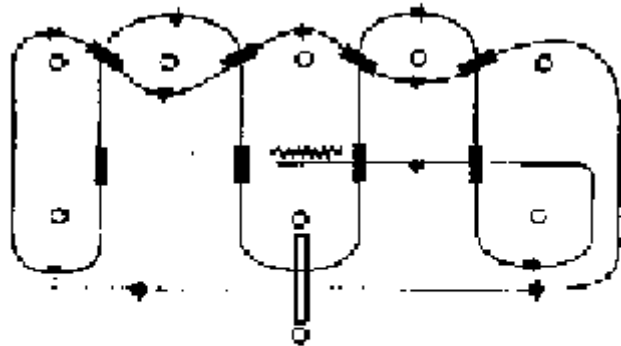

2. **Scoring** - The equine in this class will be judged on riding quality and smoothness of gaits, changes of leads, response to rider, manners, disposition and intelligence. Scoring will be based on performance and on conformation.

Flying changes of lead should be executed quietly and smoothly in the equine's performance. Contestants will be penalized when the equine changes leads in front but not in back, when the equine shows signs of resistance to lead changes (tail wringing, head tossing, etc.). When the equine is asked to go over the obstacle, he should do so smoothly and calmly. When asked to back, he should do so in a relaxed, obedient manner.

3. **Class Routine**

- a) All equines shall follow the exact pattern as illustrated in this book unless specific changes are indicated in the show rules. Any equine not following the exact pattern will be disqualified.
- b) The eight small circles in the pattern represent markers (plastic or rubber cone-shaped markers recommended). These should be spaced a uniform distance apart. The preferred distance lengthwise between the markers is 40', but if arena space is limited, they may be spaced as necessary. See diagram above.
- c) The rectangle represents an object just high enough to break the equine's stride. A small log or ground pole is recommended.
- d) The long and sometimes twisting line indicates the direction to travel and the gaits at which the equine is to move. The dotted (...) line indicates the walk; the dash (---) line, the trot; and the solid (—) line, the lope.

NYS 4-H Western Division

- e) The exhibitor will enter their equine in the ring and then proceed on the pattern as indicated. In completing the pattern, the rider will go to the center of the pattern and back their equine as indicated by the judge.
- f) If a equine runs into a marker, the exhibitor should be penalized but not disqualified.
- g) Only one hand on the reins will be allowed. The method of holding the reins is the same as described for Stock Seat Equitation. While the equine is in motion, the rider's hands should be clear of the equine and saddle.
- h) Spurs shall not be used forward of the cinch.

4. **Disqualifications**

- a) Fall of equine or rider.
- b) Off pattern which includes failure to obtain the required gaits.
- c) Use of prohibited tack or appointments.

D. Western Reining - Each entry will individually perform a required pattern as selected and posted prior to the beginning of the show. The equine should rein and handle easily, fluently, effortlessly and with reasonable speed throughout the pattern. Any equine not following the exact course of travel indicated in the pattern will be disqualified.

1. **Class Routine**

- a) Each contestant to follow the exact reining pattern that is posted.
- b) The judge shall inspect the curb strap or chain of each contestant immediately after running the pattern.

2. **Scoring** - Scoring will be on the basis of 60-80%, with 70% noting an average performance. Each equine will be judged on the neatness, dispatch, ease, calmness and speed with which it performs the pattern. The score may be affected by faults of both the equine and rider.

- a) Faults against the equine which will be penalized but which will not be cause for **disqualification** are:
 - 1) Opening mouth excessively.
 - 2) Breaking gaits.
 - 3) Excessive jawing of the bit, open mouth or head raising on stops.
 - 4) Lack of smooth, straight stop on haunches (bouncing or sideways stop).
 - 5) Refusing to change leads or changing leads in front but not in back.
 - 6) Anticipating signals.
 - 7) Wringing tail.
 - 8) Backing sideways.

NYS 4-H Western Division

- 9) Backing over markers.
- b) Faults against the rider but which **will not cause disqualification** are:
 - 1) Changing hands on the reins.
 - 2) Using two hands on reins.
 - 3) Losing stirrups or holding on saddle.
 - 4) Unnecessary aid given by rider to equine (talking, petting, spurring, etc.)
 - 5) In reining patterns, failure to run figure 8 within the markers and/or roll-backs beyond the markers is to be considered a fault and not a disqualification.
 - 6) While equine is in motion, rider's hands shall be clear of the equine and saddle.
- c) Disqualifications
 - 1) Use of prohibited equipment and appointments.
 - 2) Off pattern.
 - 3) Fall of the equine and/or rider.
3. **Patterns** - The following nine patterns were taken from the AHSA 1992-93 rule book.

PATTERN #1

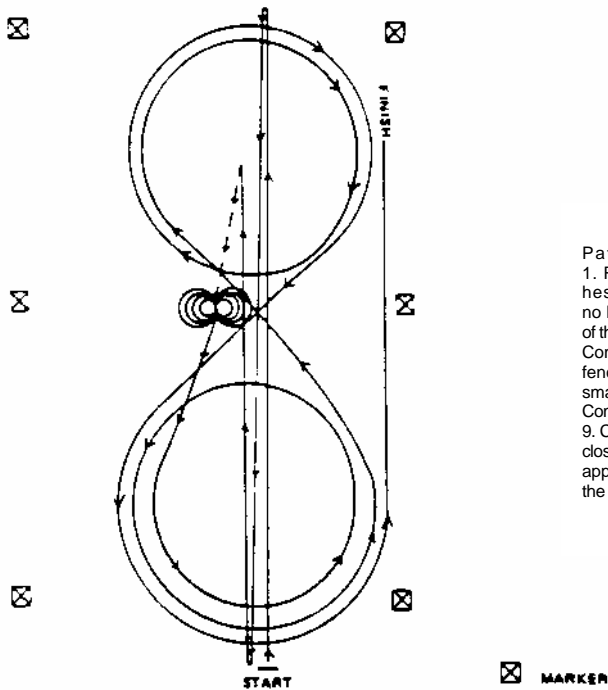

Pattern #1

1. Run at speed to the far end of the arena past end marker and do a left rollback, no hesitation.
2. Run to opposite end of the arena past end marker and do a right rollback, no hesitation.
3. Run past center of the arena, do a sliding stop, back straight to the center of the arena. Hesitate.
4. In the center of the arena, complete four spins to be right.
5. Complete four and a quarter spins to the left so that the horse is facing the wall or the fence. Hesitate.
6. Begin on left lead and complete two circles to the left. The first circle small and slow, the second circle large and fast.
7. Change leads at the center of the arena.
8. Complete two circles to the right, the first circle small and slow, the second circle large and fast.
9. Change leads at the center of the arena, end begin a large, fast circle to the left. Do not close the circle. Run straight down the side of the arena past center and do a sliding stop approximately 20 feet from wall or fence.
10. Hesitate to demonstrate the completion of the pattern.
11. Rider must drop bridle to the judge.

PATTERN #2

Pattern #2

1. Begin at the center of the arena. Complete two circles to the right. The first circle small and slow, the second circle large and fast.
2. Change leads at the center of the arena.
3. Complete two circles to the left, the first circle small and slow, the second circle large and fast.
4. Change leads at the center of the arena.
5. Run to the far end of the arena-past end marker and do a left rollback. No hesitation.
6. Run to opposite end of arena-past end marker and do a right rollback, no hesitation.
7. Run past center of arena and do a sliding stop.
8. Back straight to the center of the arena. Hesitate.
9. Complete four spins to the right.
10. Complete four spins to the left.
11. Hesitate to demonstrate the completion of the pattern.
12. Rider must drop bridle to the judge.

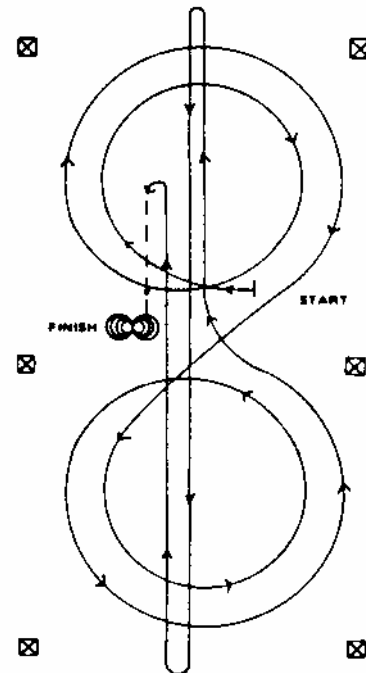

PATTERN #3



Pattern #3

1. Begin approximately 20 feet from the left wall or fence on the right lead.
2. Lope straight down the side of the arena staying 20 feet from the fence, circle the top end of the arena and run straight down opposite side past center marker and do a left rollback.
3. Continue straight down the side at least 20 feet from the wall or fence and back around top of arena (horse to be on left lead at this point) running straight down the other side of arena at least 20 feet from the wall, past center marker, and do a right rollback.
4. Continue up the left side of arena to Center marker, and at center marker horse should be on right lead: continue to center of arena on right lead.
5. Complete two circles to the right, the first circle small and slow. The second circle large and fast. Change leads at the center of arena.
6. Complete two circles to the left the first circle small and slow, the second circle large and fast. Change leads at the center of the arena.
7. Begin a large, fat circle to the right - do not close this circle.
8. Continue straight down the side at least 20 feet from wall or fence, circle the end of the arena and run straight down the opposite side of the arena past center marker and do a sliding stop-at least 20 feet from the wall. Back up at least 10 feet. Hesitate.
9. Complete four spins to the right and four spins to the left.
10. Hesitate to demonstrate the completion of the pattern.
11. Rider must drop bridle to the judge.

PATTERN #4

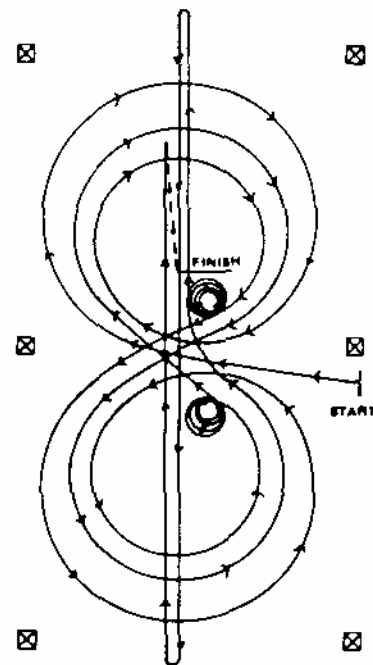

Pattern #4

1. Begin at the center of the arena. Complete two circles to the right, the first circle large and fast, the second circle small and slow.
2. At the center of the arena, stop and complete four spins to the right - horse to be facing left wall or fence. Hesitate.
3. Begin on the left lead and complete two circles to the left; the first circle large and fast, the second circle small and slow.
4. At the center of the arena, stop and complete four spins to the left - horse to be facing left wall or fence. Hesitate.
5. Begin on right lead and make a figure eight on top of the large circles.
6. Close figure eight end change leads in the center of the arena.
7. Run to the far end of the arena past end marker end do a left rollback, no hesitation.
8. Run to opposite end of arena - past end marker and do a right rollback, no hesitation.
9. Run past the center of the arena and do a sliding stop.
10. Back straight to the center of the arena or at least 10 feet. Hesitate to demonstrate the completion of the pattern.
11. Rider must drop bridle to the judge.

PATTERN #5

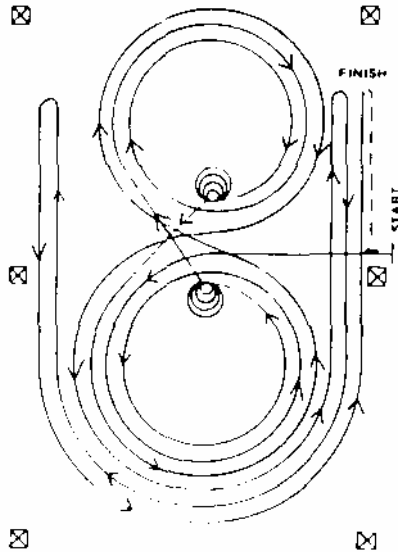

Pattern #5

1. Begin at the Center of the arena facing left wall or fence. Begin on left lead and complete two circles to the left; the first circle large and fast, the second circle small and slow. 2. At center of the arena stop and complete four spins to the left. Horse to be facing left wall or fence. Hesitate. 3. Begin on the right lead. Complete two circles to the right: the first one large and fast, the second one small and slow. 4. At the center of the arena, stop and complete four spins to the right. Horse to be facing the wall or fence. Hesitate. 5. Begin on left lead and make a figure eight at top of the large circles. 6. Close figure eight and begin a large, fast circle to the left. Do not close this circle, but run straight down the side past center marker and do a right rollback at least 20 feet from the wall or fence. No hesitation. 7. Continue back around previous circle; do not close this circle, but run straight down opposite side of the arena past center marker and do a left rollback at least 20 feet from wall or fence. No hesitation. 8. Continue back around previous circle, do not close this circle but run straight down the side past Center marker and do a sliding stop at least 20 feet from wall or fence 9. Back *overslide* tracks a minimum of 10 feet. 10. Hesitate to demonstrate the completion of the pattern. 11. Rider must *drop* bridle to the judge.

PATTERN #6

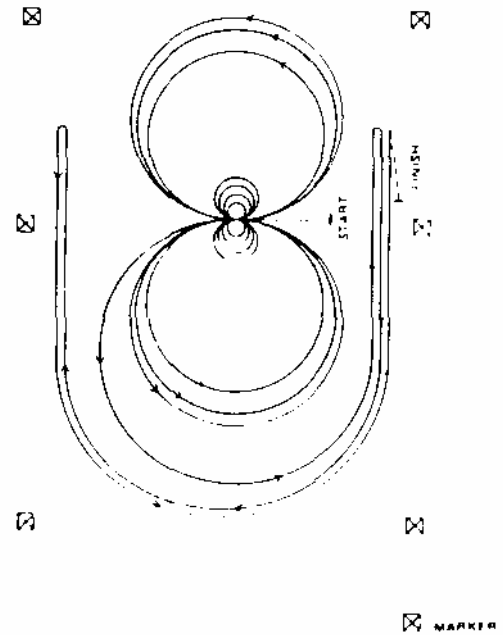

Pattern #6

1. Walk in the center of the arena and complete four spins to the right. Hesitate. 2. Complete four spins to the left. Hesitate 3. Begin on the left lead, complete two large large, fast circle to the left. Do not close this circle, but run down the side past the center marker and do a right rollback at least 20 feet from the wall or fence. 6. Continue back around previous circle; run down opposite side of arena past center marker and do a left rollback at least 20 feet from wall or fence. 7. Continue back around the previous circle. Do not close this circle, but run down the side past the center marker and do a sliding stop. Back straight to the center of the arena or at least 10 feet. 6. Hesitate to demonstrate the completion of the pattern. 9. Rider must drop bridle to the judge.

PATTERN #7

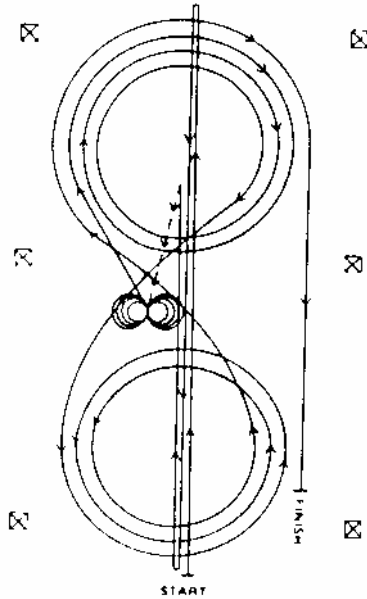

Pattern #7

1. Run at speed to the far end of the arena past the end marker and do a left rollback. No hesitation. 2. Run to the opposite end of the arena past end marker and do a right rollback. No hesitation. 3. Run past center of arena, do a sliding stop; back straight to the center of the arena. Hesitate. 4. Complete four spins to the right. 5. Complete four and a quarter spins to the left. Hesitate. 6. Begin on the right lead, complete three circles to the right, the first two circles large and fast the third circle small and slow. 7. At the center of the arena, change leads. 8. Complete three circles to the left, the first two circles large and fast, the third circle small and slow. 9. At the center of the arena, change leads. 10. Begin a large, fast circle to the right. Do not close this circle, but run straight down the side of the arena past the center marker and do a sliding stop approximately 20 feet from the wall or fence. 11. Hesitate to demonstrate the completion of the pattern. 12. Rider must drop bridle to the judge

PATTERN #8

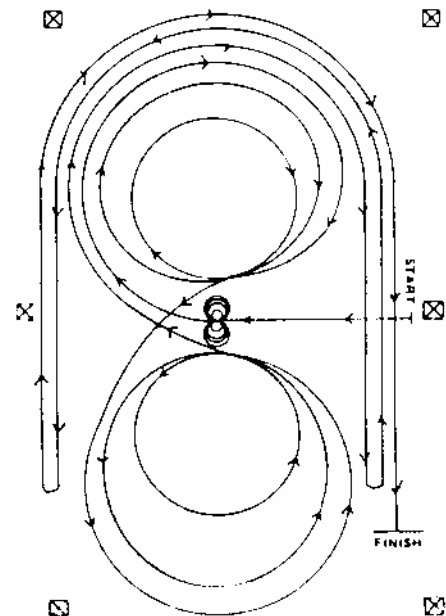

Pattern #8

1. Begin at center- horse should be facing left wall or fence. 2. Complete four spins to the left. 3. Complete four spins to the right. Hesitate. 4. Begin on right lead and complete three circles to the right. The first circle large and fast, the second circle small and slow, the third circle large and fast. 5. Change leads at center of the arena. 6. Complete three circles to the left, the first circle large and fast, the second circle small and slow, the third circle large and fast. 7. Change leads at center of the arena. 8. Begin a large, fast circle to the right; Do not close this circle but run straight down the side past center marker and do a left rollback at least 20 feet from wall or fence, no hesitation. 9. Continue back around top half of previous circle, do not close this circle but run straight down opposite side of the arena past Center marker and do a right rollback at least 20 feet from wall or fence, no hesitation. 10. Continue back around previous circle, do not close this circle but run straight down the side past the center marker and do a sliding stop at approximately 20 feet from wall or fence. 11. Back straight to center of arena or at least 10 feet. 12. Hesitate to demonstrate the completion of the pattern. 13. Rider must drop bridle to the judge.

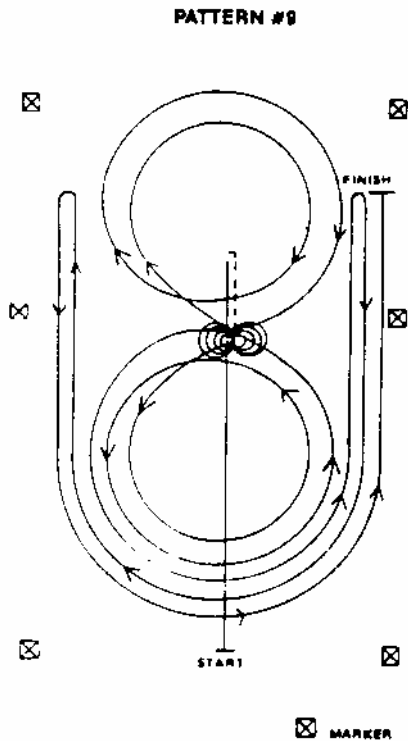

Pattern #9

1. Run past center marker and do a sliding stop. 2. Back straight to the center of the arena Hesitate. 3. Complete four spins to the right. 4. Complete four and a quarter spins to the left. Hesitate. 5. Begin on left lead. Complete two circles to the left; the first circle small and slow, the second circle large and fast. 6. Change leads at center of tie arms. 7. Complete two circles to the right; the first circle small and slow the second circle large and fast 8. Change leads at the center of the arena. 9. Begin a large, fast circle to the left. Do not close the circle, but run straight down the side past center marker and do a right rollback at least 20 feet from wall or fence, no hesitation 10. Continue back around top half of previous circle. Do not close in circle but run straight down opposite side of the arena past center marker and do a left rollback at least 20 feet from wall or fence, no hesitation 11. Continue back around previous circle; do not close this circle but run straight down the side past the center marker and do a sliding stop at least 20 feet from wall or fence. 12. Hesitate to demonstrate the completion of the pattern. 13. Ruder must drop bridle 10 the Judge.

*Horse may come out of rollback on either lead, however horse should be on correct lead when rounding the end of the arena.

- E. Horsemanship Class** - All exhibitors must perform an individual pattern which is not to exceed 1 minute. Pattern will be of the judge's choosing and will be posted prior to the beginning of the class.

The judge may use the individual work to determine the top riders that will be called back for rail work; this procedure will be optional and at the judge's discretion.

Tack, equipment and riding style shall be as in Stock Seat Equitation.

- F. Western Road Hack Class** - Equines are to be shown at a walk, jog, extended jog, lope and extended lope both ways of the ring. The equine should be similar to the Western Pleasure mount in that it should move in a consistent, relaxed and willing manner.

1. **Scoring** - Emphasis in this class will be placed on the equine's ability to show a moderate lengthening in strides when softly cued. Equines should remain smooth and consistent throughout all gaits and transitions.

2. **Class Routine**

- a. Gaits

NYS 4-H Western Division

- 1) The walk is a natural, flat-footed four-beat gait. The equine must move straight and true at the walk. The walk must be alert, with a stride of reasonable length in keeping with the size of the equine.
 - 2) The jog is a smooth ground-covering two-beat diagonal gait. The equine works from one pair of diagonals to the other pair. The jog should be square, balanced and with a straight, forward movement of the feet. Equines walking with their back feet and trotting on the front are not considered performing the required gait.
 - 3) The extended jog is a moderate lengthening of stride; ability to extend stride rather than merely increasing speed. The rider should sit to the extended jog, not post.
 - 4) The lope is an easy, rhythmical three-beat gait. Equines moving to the left should lope on the left lead. Equines moving to the right should lope on the right lead. Equines travelling at a four-beat gait are not considered to be performing at a proper lope. The equine should lope with a natural stride and appear relaxed and smooth. He should be ridden at a speed that is natural in way of going.
 - 5) The extended lope is a moderate lengthening of stride; ability to extend stride rather than merely increasing speed.
- b) All equines will enter the ring in a counterclockwise direction at a walk until otherwise directed by the judge. They will then show in all gaits specified above, then asked to reverse and show in all gaits as specified above in that direction. The reverse should be done by turning away from the rail.
 - c) After all equines have been worked, the judge may then excuse equines not to be considered further in the class.
 - d) The judge may ask for additional work from any of the remaining equines.
 - e) All equines being considered for an award shall be asked to back in a straight line a minimum of 3 steps.
 - f) Only one hand is to be used for reining. The hand chosen (either right or left) shall not be changed during the class. If a rope is carried on the saddle, it must be attached to the side opposite the reining hand. One finger is allowed between the reins except when romal reins are used. The rider may hold the romal or ends of the split reins provided it is held at least 16" from the reining hand.

IV. **JUNIOR EQUINES MAY BE SHOWN IN A SNAFFLE BIT OR BOSAL**

A. Junior equines will be 3-5 years of age. The following criteria must be met.

1. If a registered animal, the age of the equine will be determined from the registration papers. The age of the equine shall be computed on the basis of a calendar year starting January 1 of the year foaled.

For example: A equine foaled anytime in 1993 was considered to be one year old on January 1, 1994, and two years old on January 1, 1995.

If an equine is not registered, a veterinarian certificate will be required. The certificate must document the veterinarian's estimate of age as a three-, four-, or five-year old for the current show year.

Age will be estimated by the veterinarian by examination of its teeth. Determination by tooth examination is to be made in accordance with the "Official Guide for Determining Age of the Horse" as adopted by the American Association of Equine Practitioners.

The certificate must be dated January 1 through June 1 of the current year. A new certificate is required each year that an equine is shown as a junior animal in a snaffle or bosal. The veterinarian certificate must identify the equine by age, sex, color, markings, etc. similar to Coggins papers or the 4-H equine ownership certificate.

2. A equine shown as a junior animal must never have been shown in any event in a bridle (other than a snaffle bit and bridle).
3. Care and consideration of the animal must be taken when the decision is made as to which classes a junior equine will be exhibited in. A junior equine should not be shown in any class for which the training and ability level of that animal is not sufficient or the animal is unruly or posing a danger to others. The judge, ring master, division chair or equine show superintendent may dismiss a equine and rider from any class. All equines will be treated humanely. Please refer to the N.Y.S. 4-H General Equine Show Rules for clarification.
4. The equine **MUST** be shown with both hands on reins, maintaining light contact with the equine's mouth. The rider's hands should be carried near the pommel and not further than 4" out on either side of the saddle horn. The rider's hands must be steady with limited movement. Rider's hand's should be visible to the judge(s) at all times. Find acceptable and unacceptable hand positions below.

Examples of Acceptable Hand Positions.



Examples of Unacceptable Hand Positions.



These hand positions should be severely penalized.

5. The judge shall have the authority to require the removal or alteration of any piece of equipment which is unsafe, or in his opinion, would tend to give the equine an unfair advantage. Equines' mouths and noses may be inspected for signs of broken skin, rawness or bleeding. These equines will be excused from the class, the same as for any other evidence of inhumane treatment of an equine by a piece of equipment or by a rider.

6. Acceptable equipment.
 - a. Equines to be shown in standard, plain, or silver headstalls (browband, shaped ear or split ear). Smooth snaffle bit with broken mouth-piece (conventional O-ring, egg butt, or D-ring) with ring no larger than 4" and no smaller than 2". From the cheek to one inch in from the cheek must be a minimum of 3/8" diameter with a gradual decrease to the center of the snaffle. Optional loose curb strap (leather or nylon only and must be attached below the reins).

 - b. Reins are to be attached above the curb strap.

 - c. A braided rawhide or leather bosal may be used in lieu of a snaffle bit, no more than 3/4" in diameter at the cheek; must be a minimum of a 1-finger space (approximately 3/4") between the bosal and nose; absolutely no metal under the jaw or on the noseband in connection with the bosal. Bosals shall be soft and flexible. The bosal should be properly fitted relative to the equine's size and conformation. Hair bosals and mechanical hackamores are NOT permitted.

- d. Standard, leather, or woven leather split reins are mandatory, hair reins are **NOT** permitted with snaffle bits, but are acceptable with a bosal. Bosal reins are not split, but one continuous rope with a third rope rein around the horn.
- e. Training devices such as martingales, nose bands or tie downs are prohibited in the show arena and designated warm-up arena at all times. During warm up, equines must be ridden with the same equipment as required in the event.

*** PLEASE FIND TYPICAL EXAMPLES OF ACCEPTABLE BITS OR BOSAL BELOW ***

Typical examples of acceptable bits or bosal.

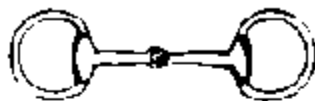

Eggbutt Snaffle Bit



O-Ring Snaffle Bit

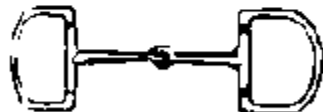

D-Ring Snaffle Bit

Rawhide Bosal



A bosal may also be used

The addition of silver engravings shall not add to or detract from the horse's performance in the judge's opinion.

*** THESE RULES PATTERNED AFTER THE NATIONAL SNAFFLE BIT ASSOCIATION RULES FROM THE 10TH EDITION REVISED JANUARY 1, 1995 ***